



(19) **United States**

(12) **Patent Application Publication**
Lavian et al.

(10) **Pub. No.: US 2011/0225330 A1**

(43) **Pub. Date: Sep. 15, 2011**

(54) **PORTABLE UNIVERSAL COMMUNICATION DEVICE**

(52) **U.S. Cl. 710/63**

(76) **Inventors: Tal Lavian, Sunnyvale, CA (US); Zvi Or-Bach, San Jose, CA (US)**

(57) **ABSTRACT**

(21) **Appl. No.: 13/113,825**

Embodiments of the invention provide a portable device comprising at least one processor. The portable device also comprises a memory coupled to the processor comprising data. Further, the portable device comprises a detector configured to detect at least one external device. The at least one external device is configured to connect to the portable device. Further, the portable device comprises an interface to connect to the at least one external device. The interface is configured to transmit or receive one or more control signals excluding the data. Furthermore, the portable device comprises a controller configured to enable controlling of the portable device from the at least one external device; and controlling of the at least one external device from the portable device through the interface.

(22) **Filed: May 23, 2011**

Related U.S. Application Data

(63) Continuation-in-part of application No. 12/699,618, filed on Feb. 3, 2010.

Publication Classification

(51) **Int. Cl. G06F 13/12 (2006.01)**

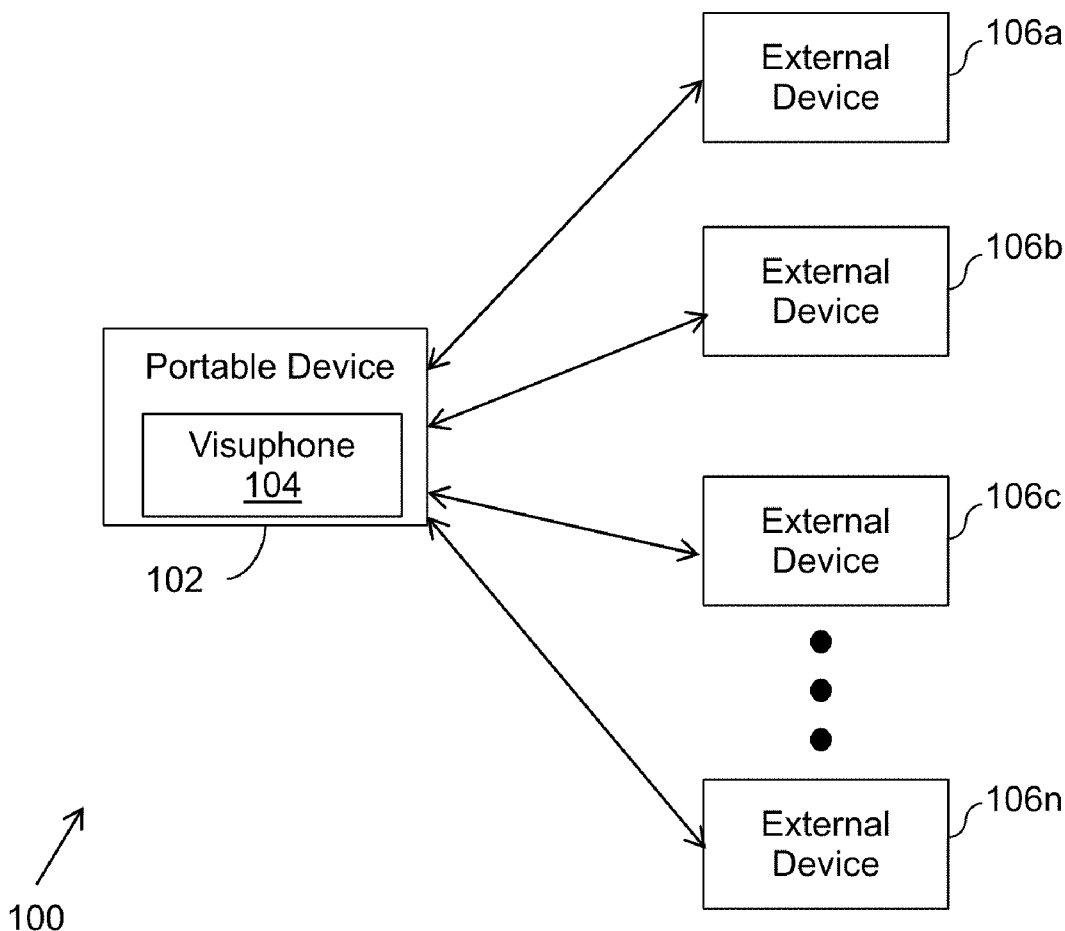

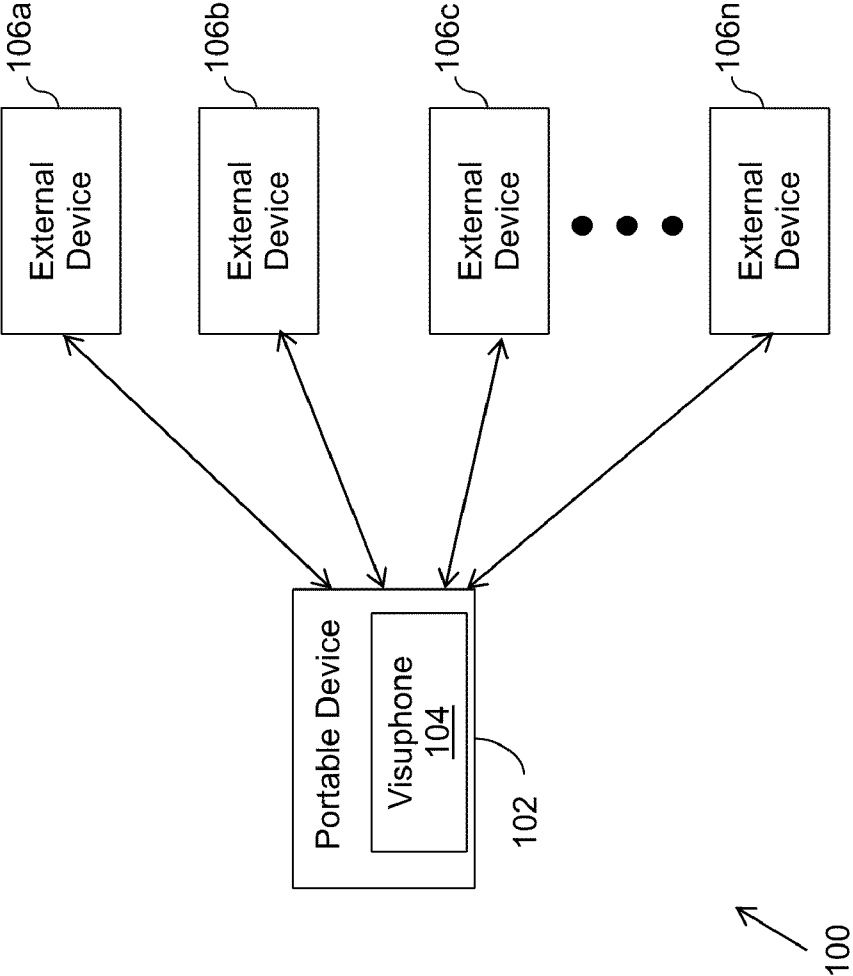

FIG. 1

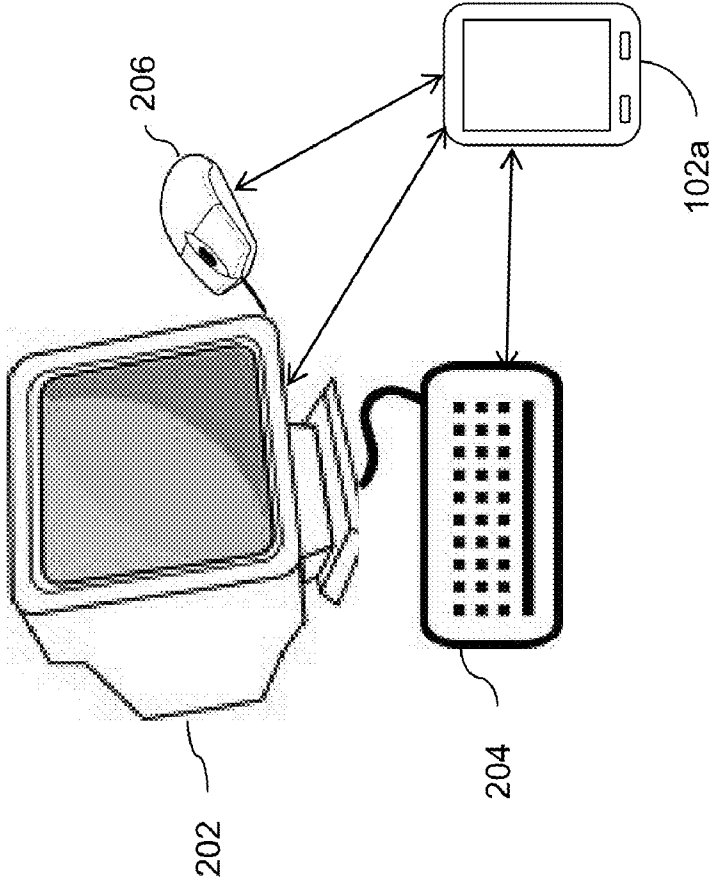

FIG. 2

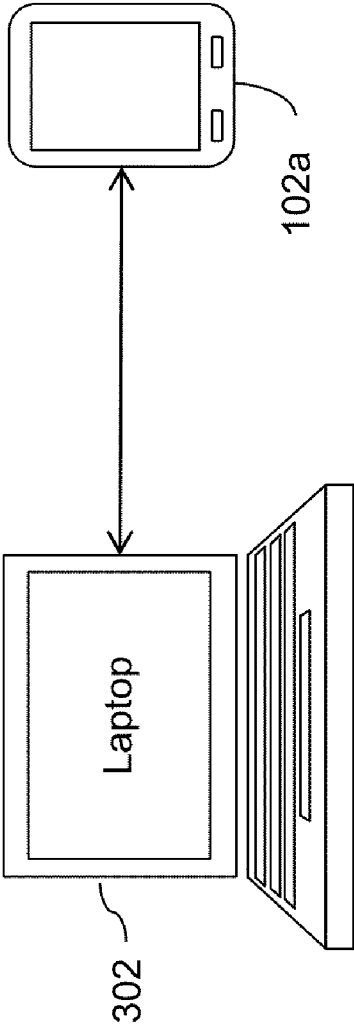

FIG. 3

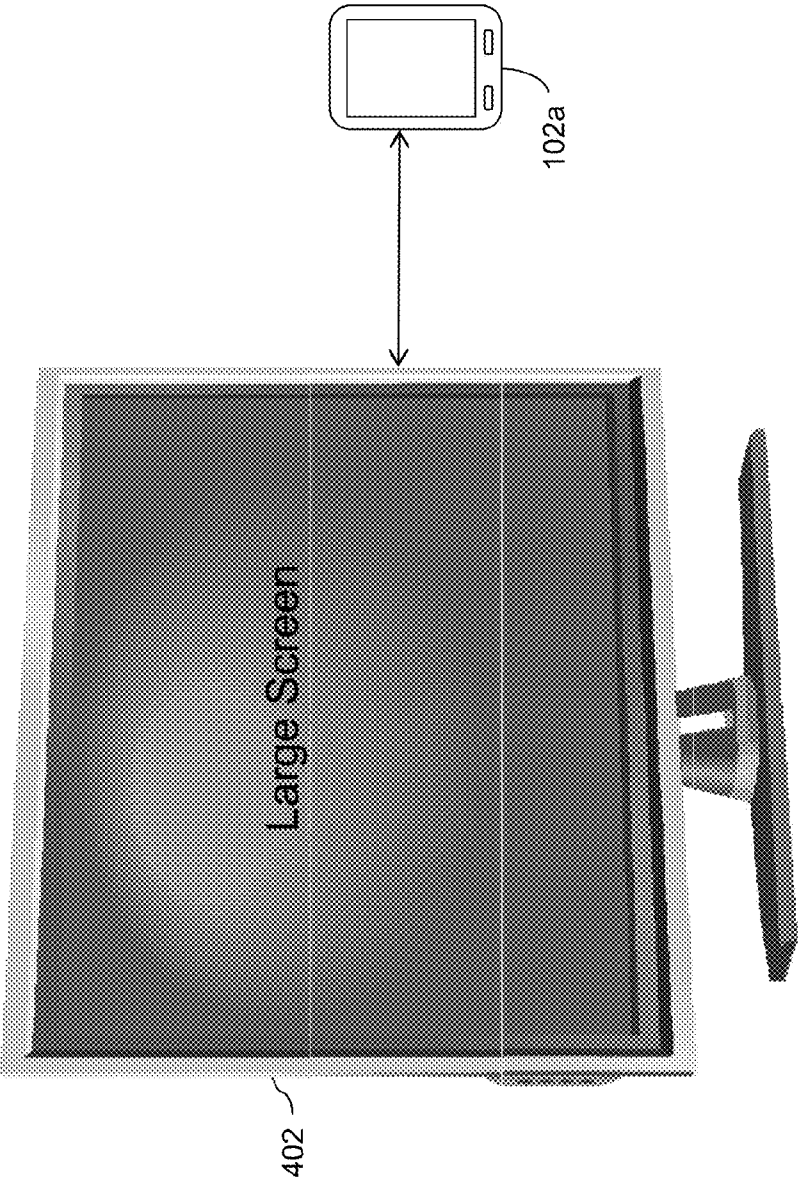

FIG. 4

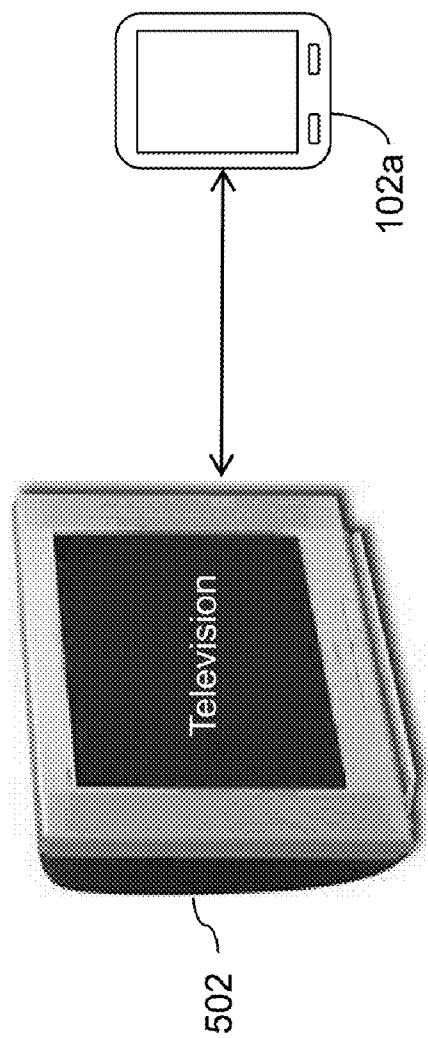

FIG. 5

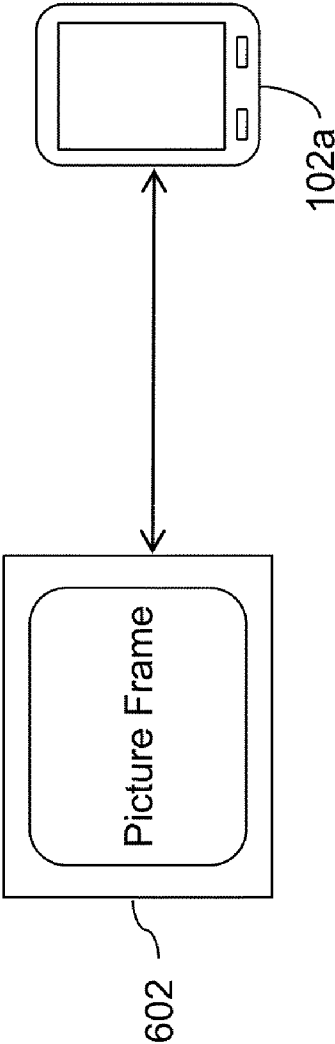

FIG. 6

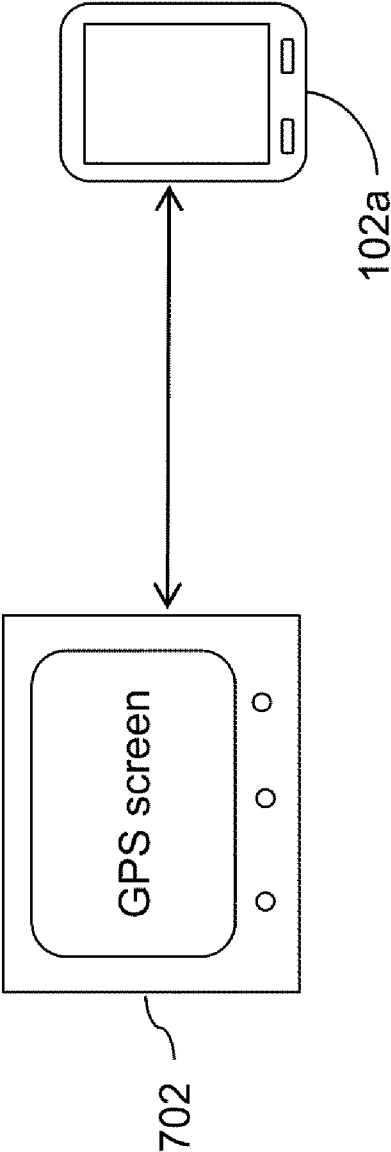

FIG. 7

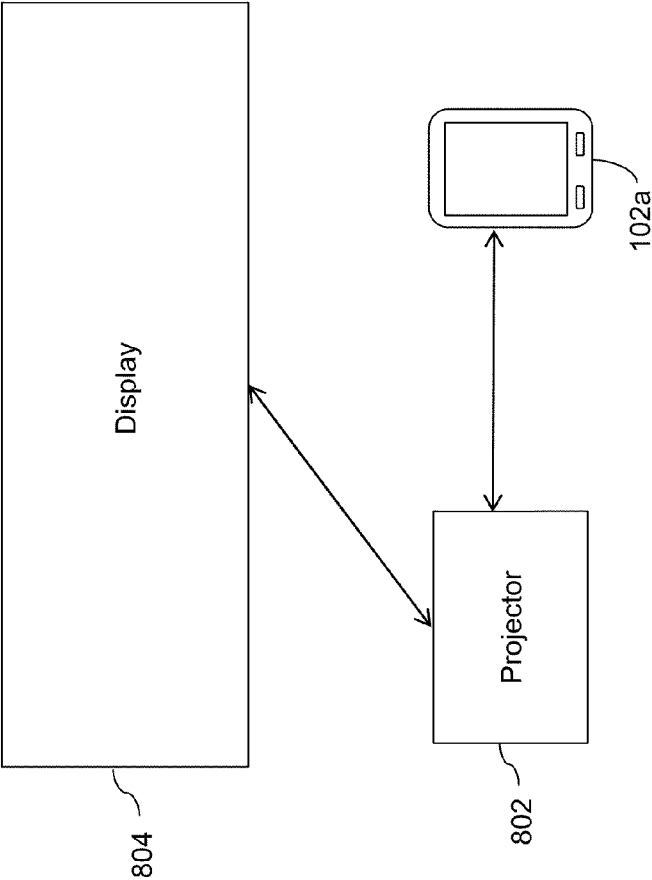

FIG. 8

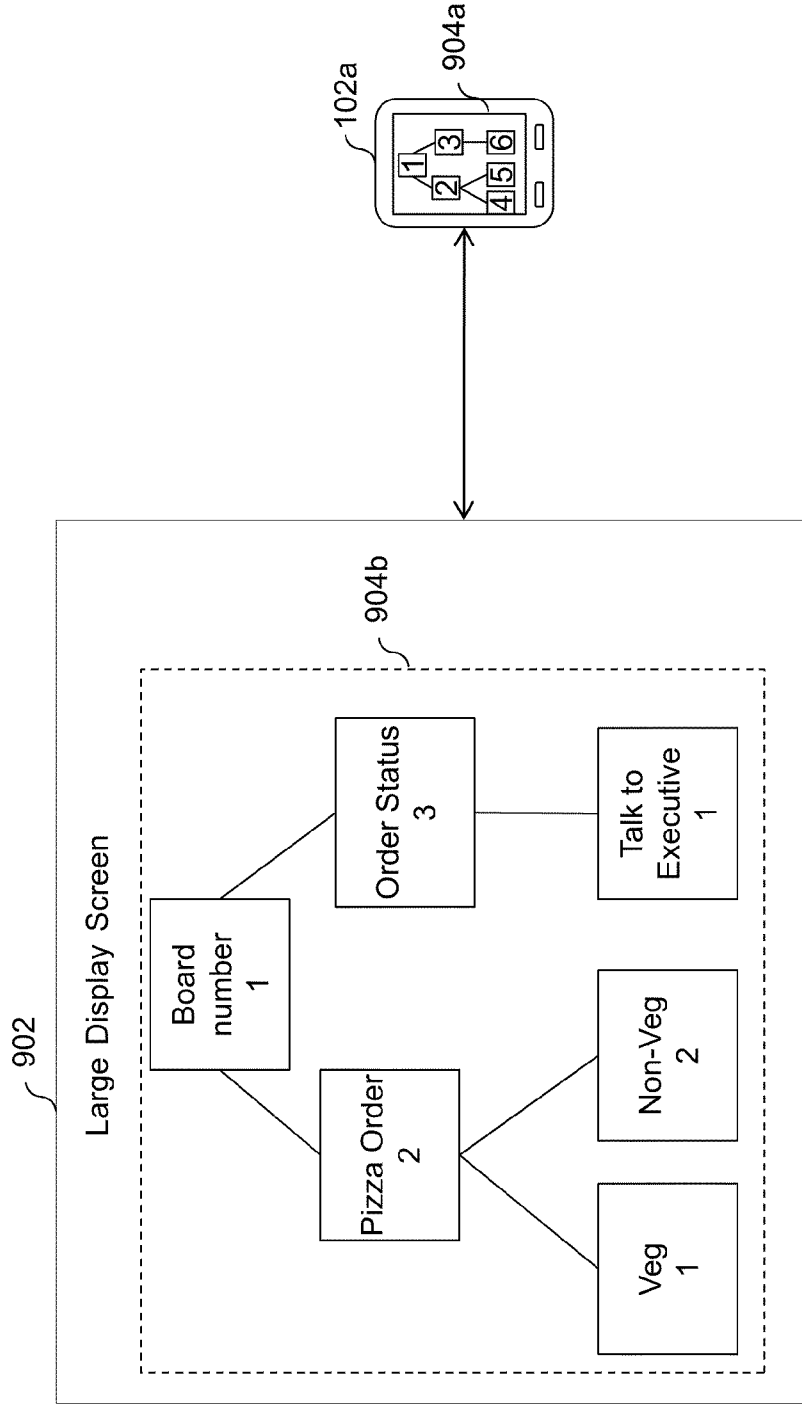

FIG. 9

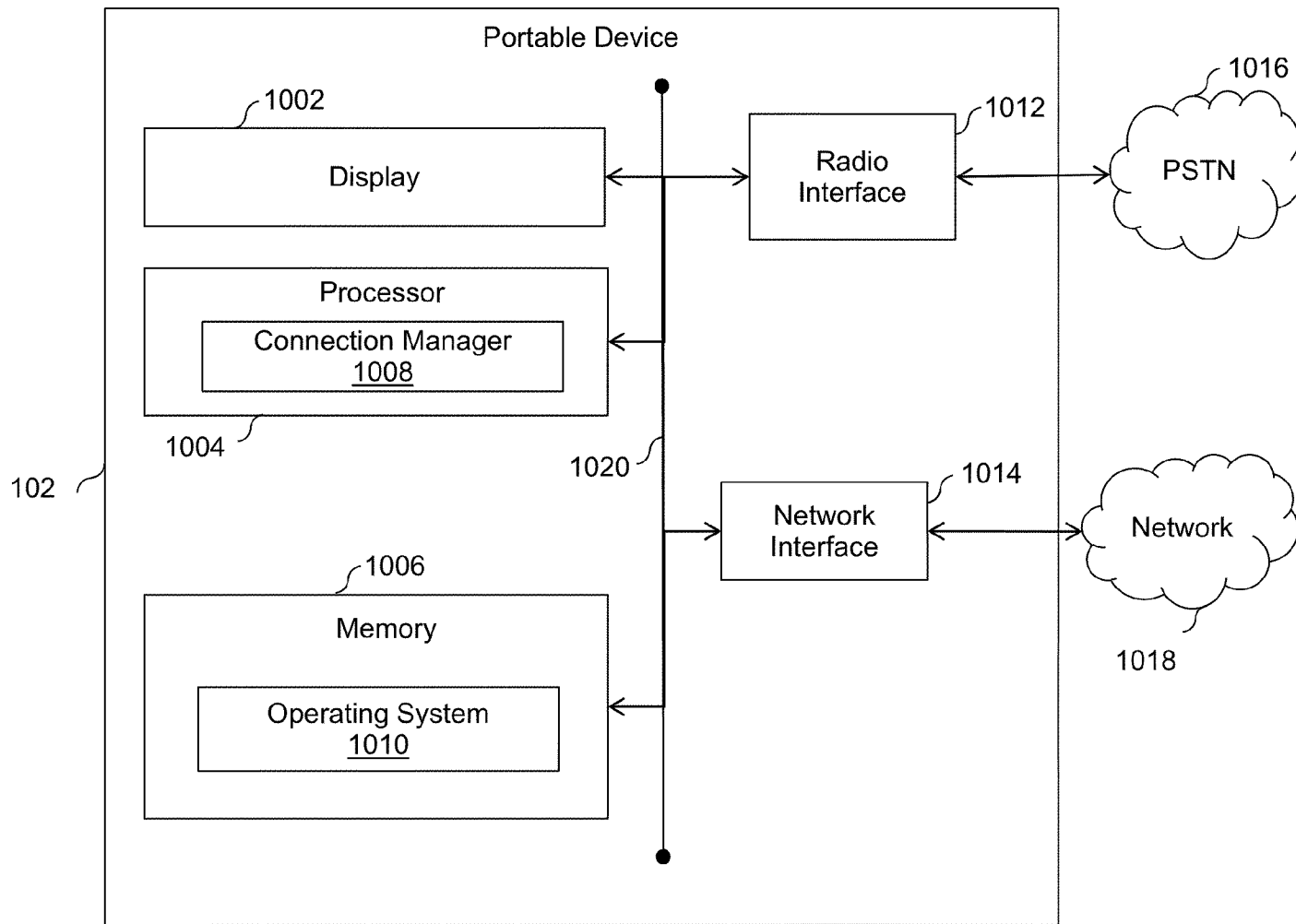

FIG. 10

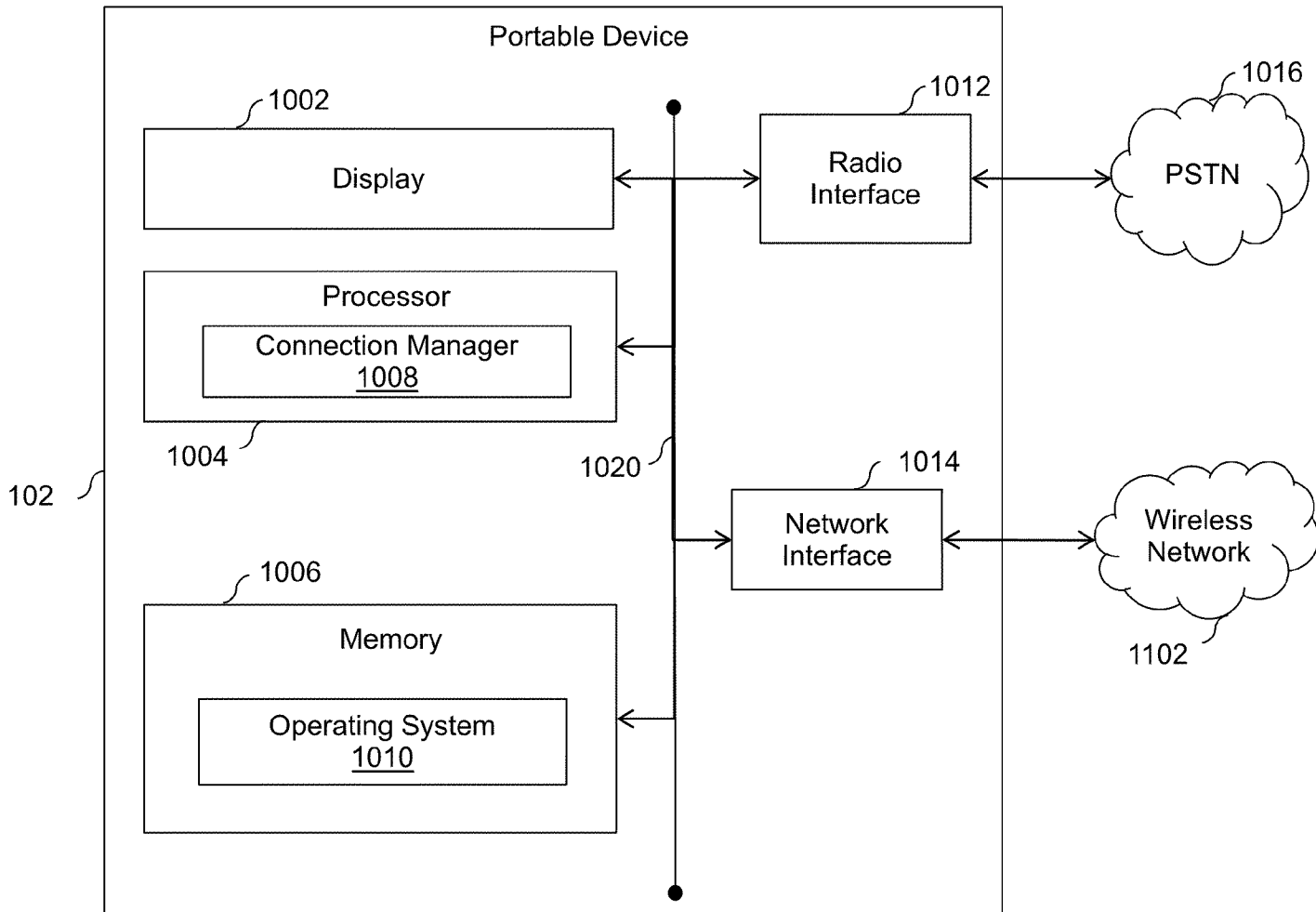

FIG. 11

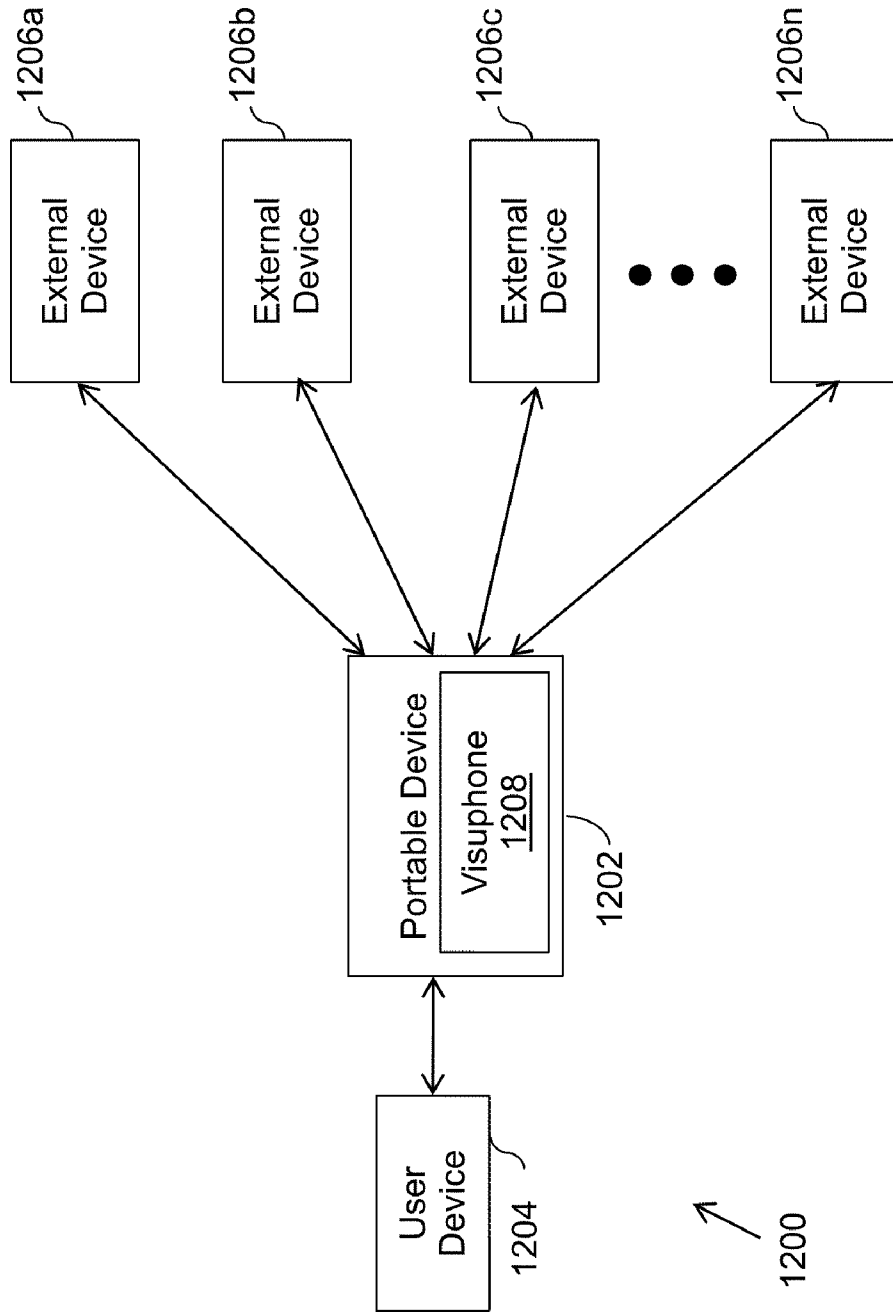

FIG. 12

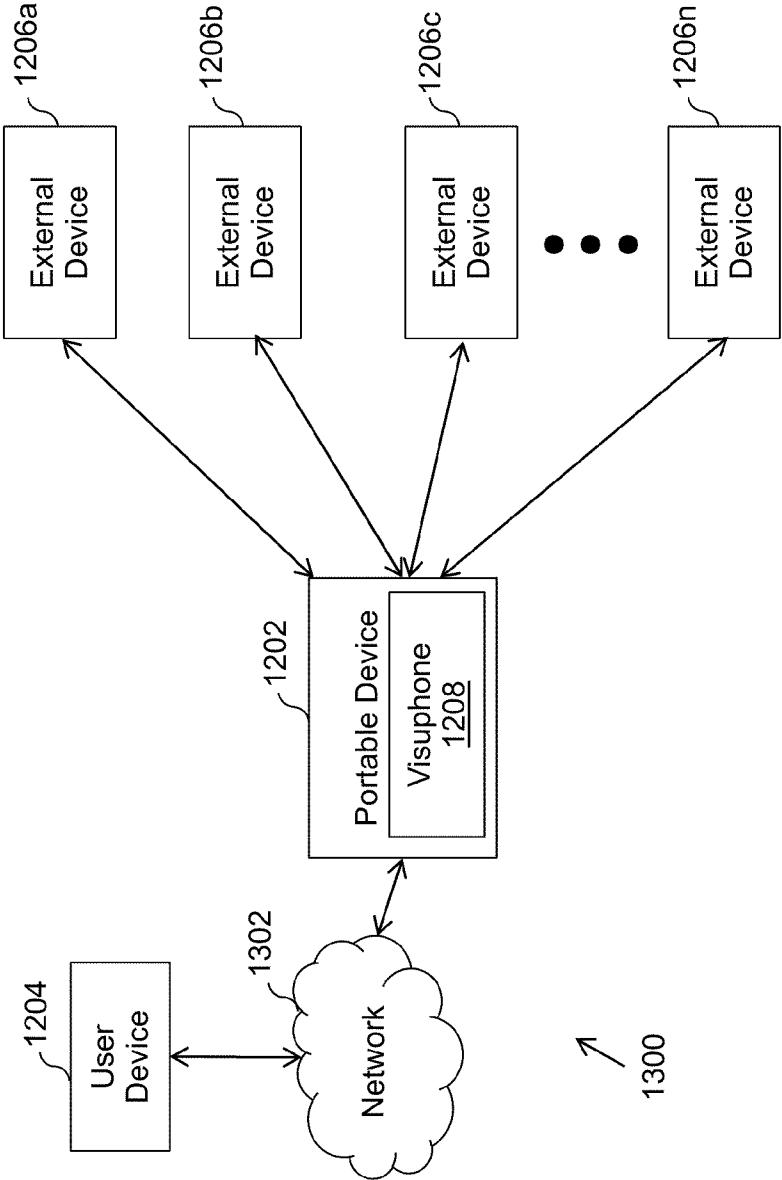

FIG. 13

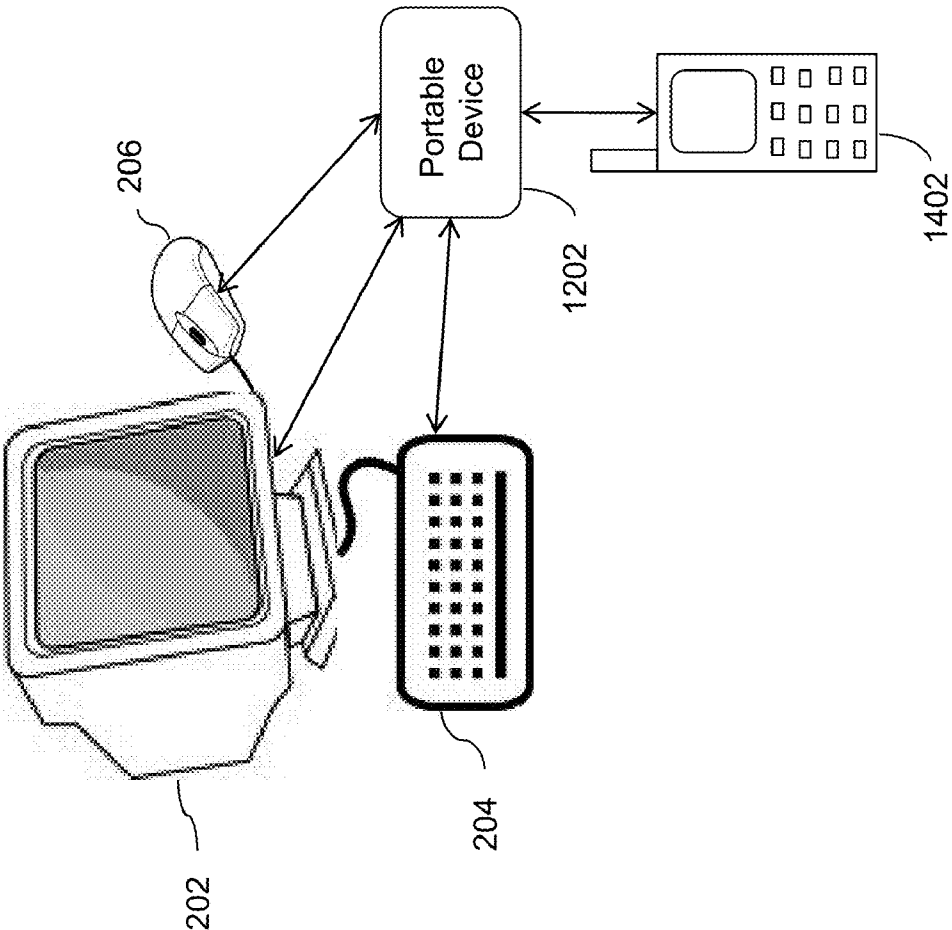

FIG. 14

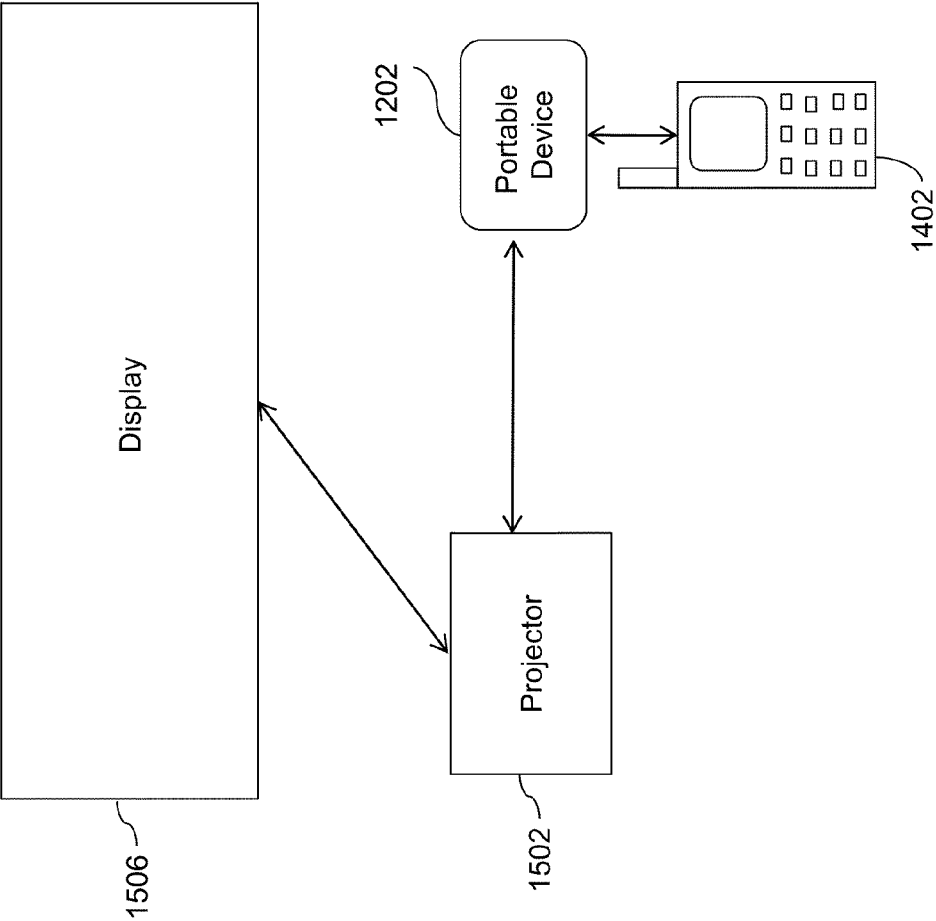

FIG. 15

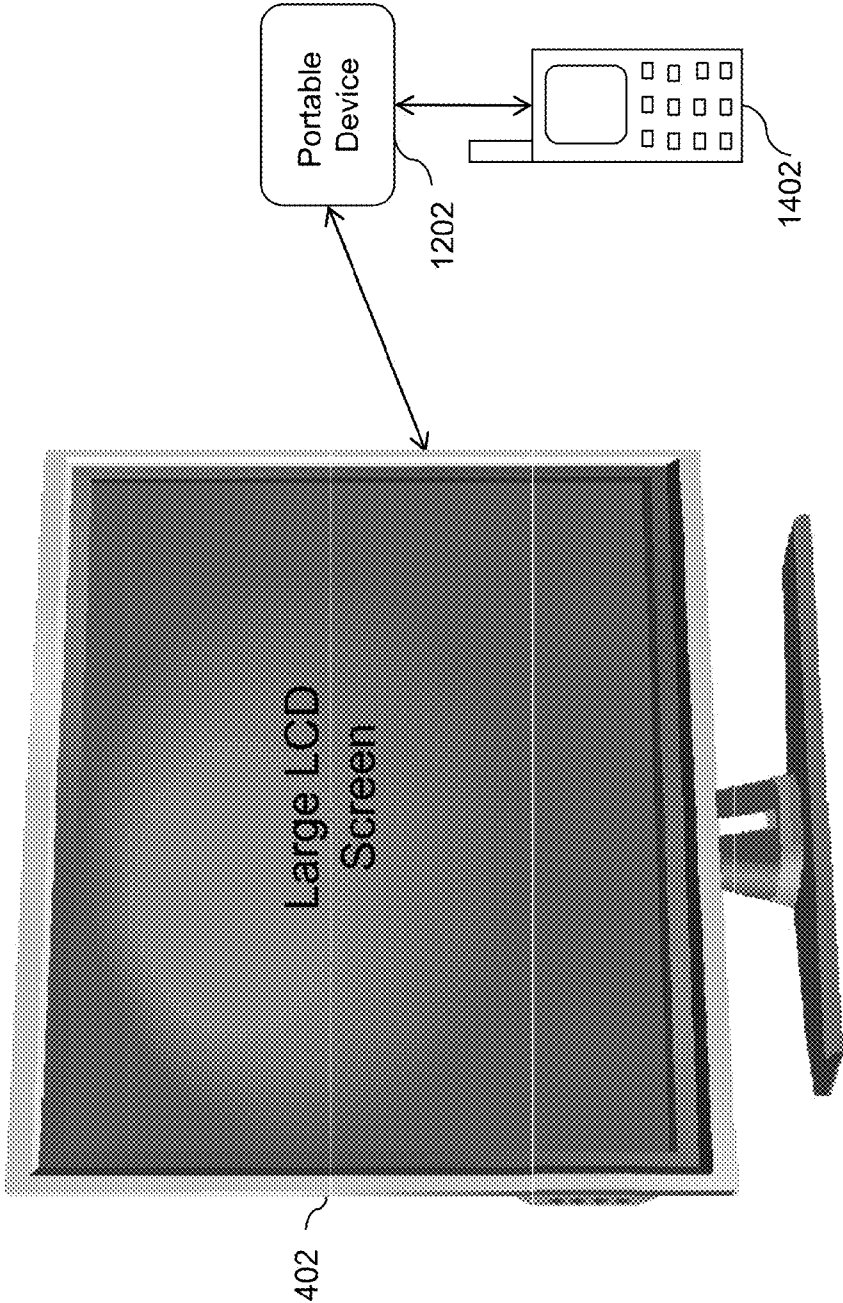

FIG. 16

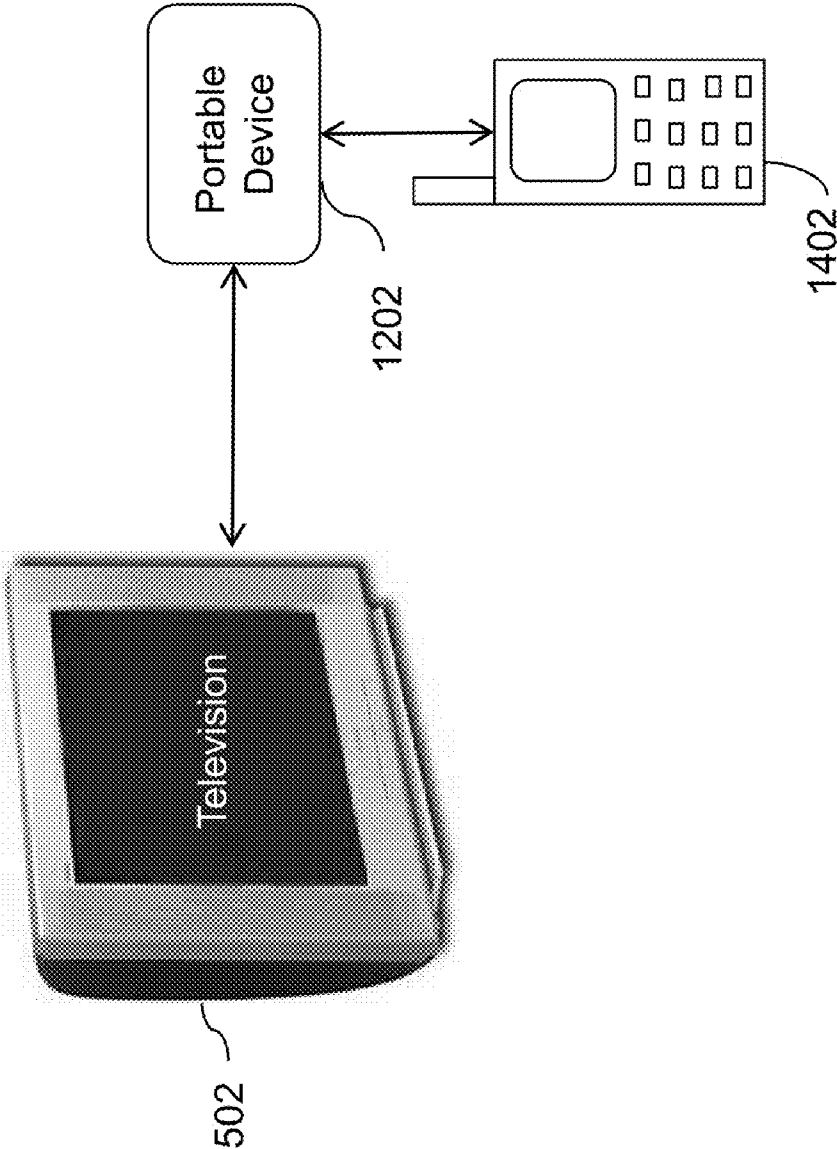

FIG. 17

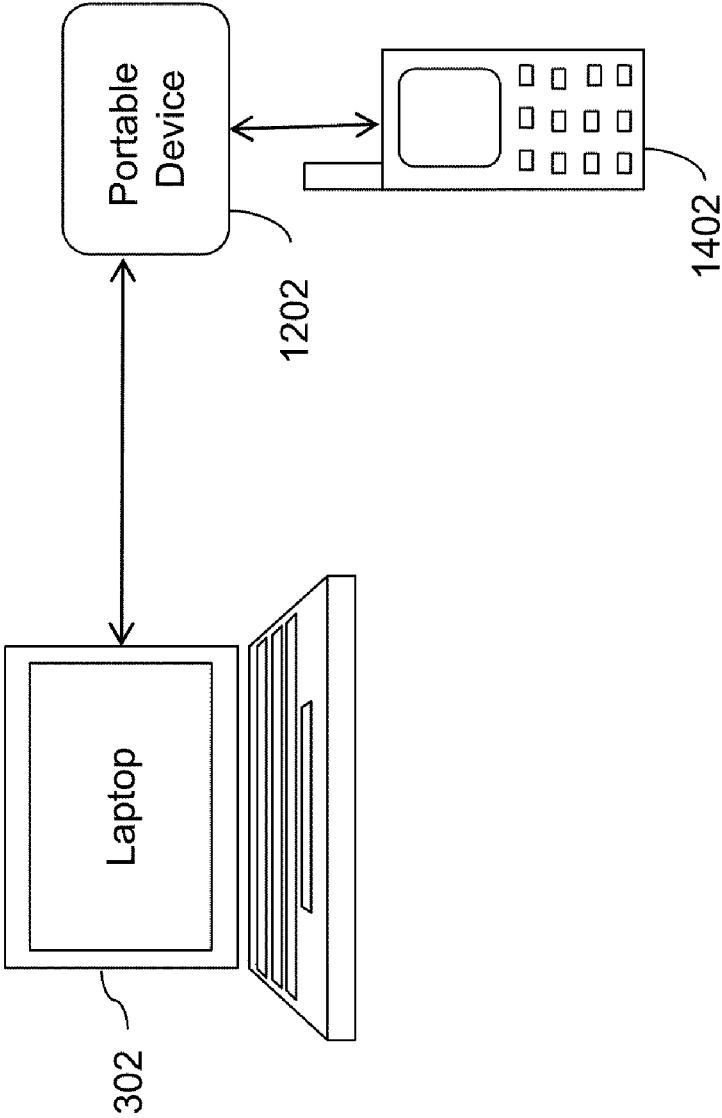

FIG. 18

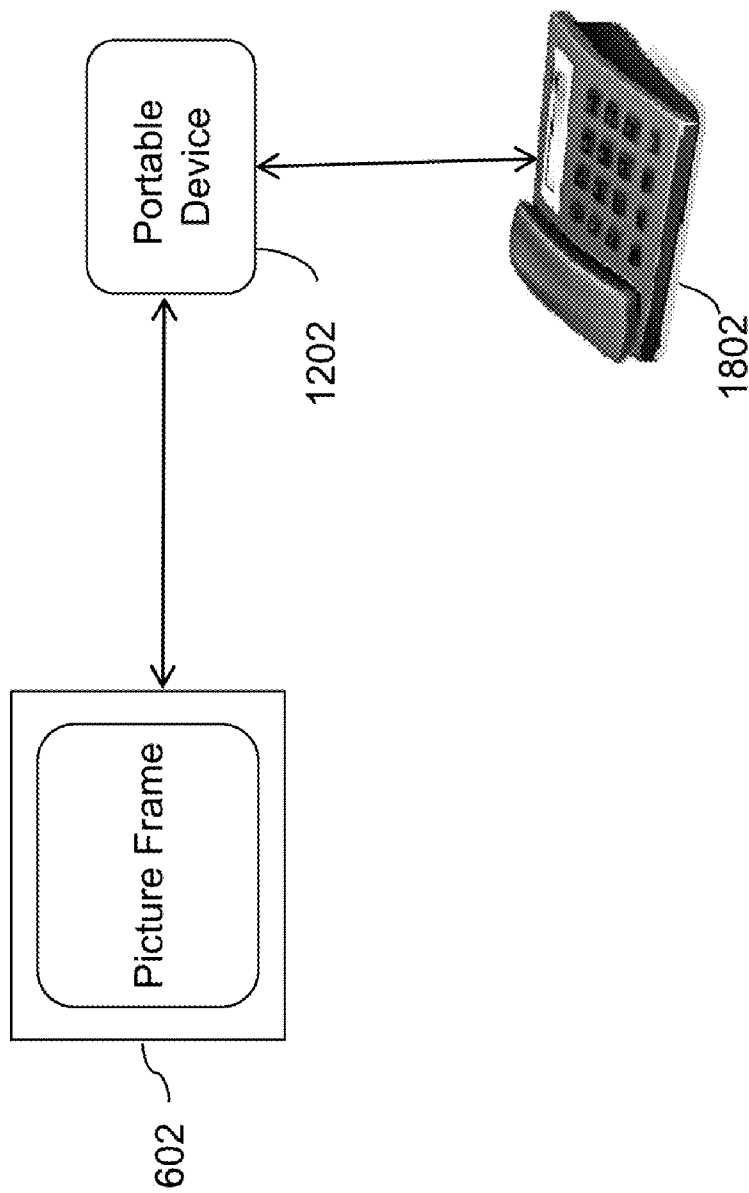

FIG. 19

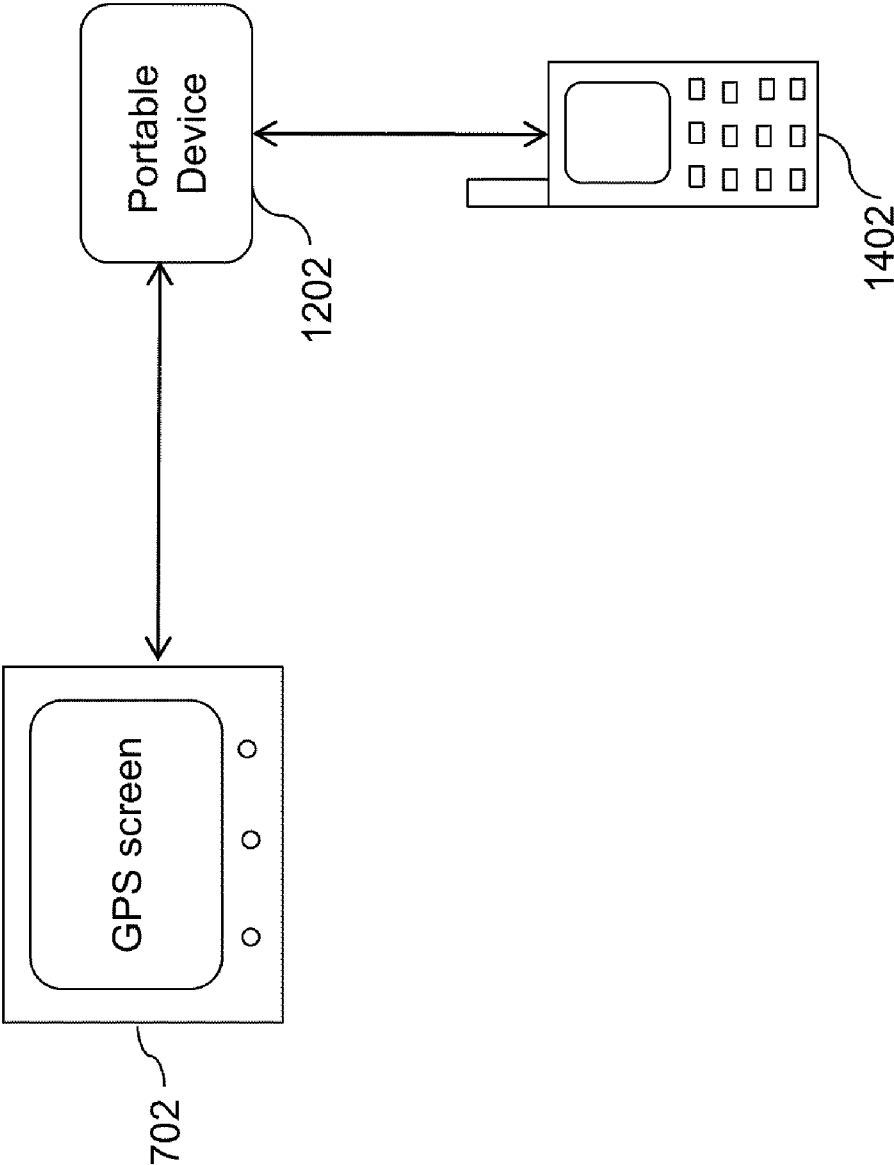

FIG. 20

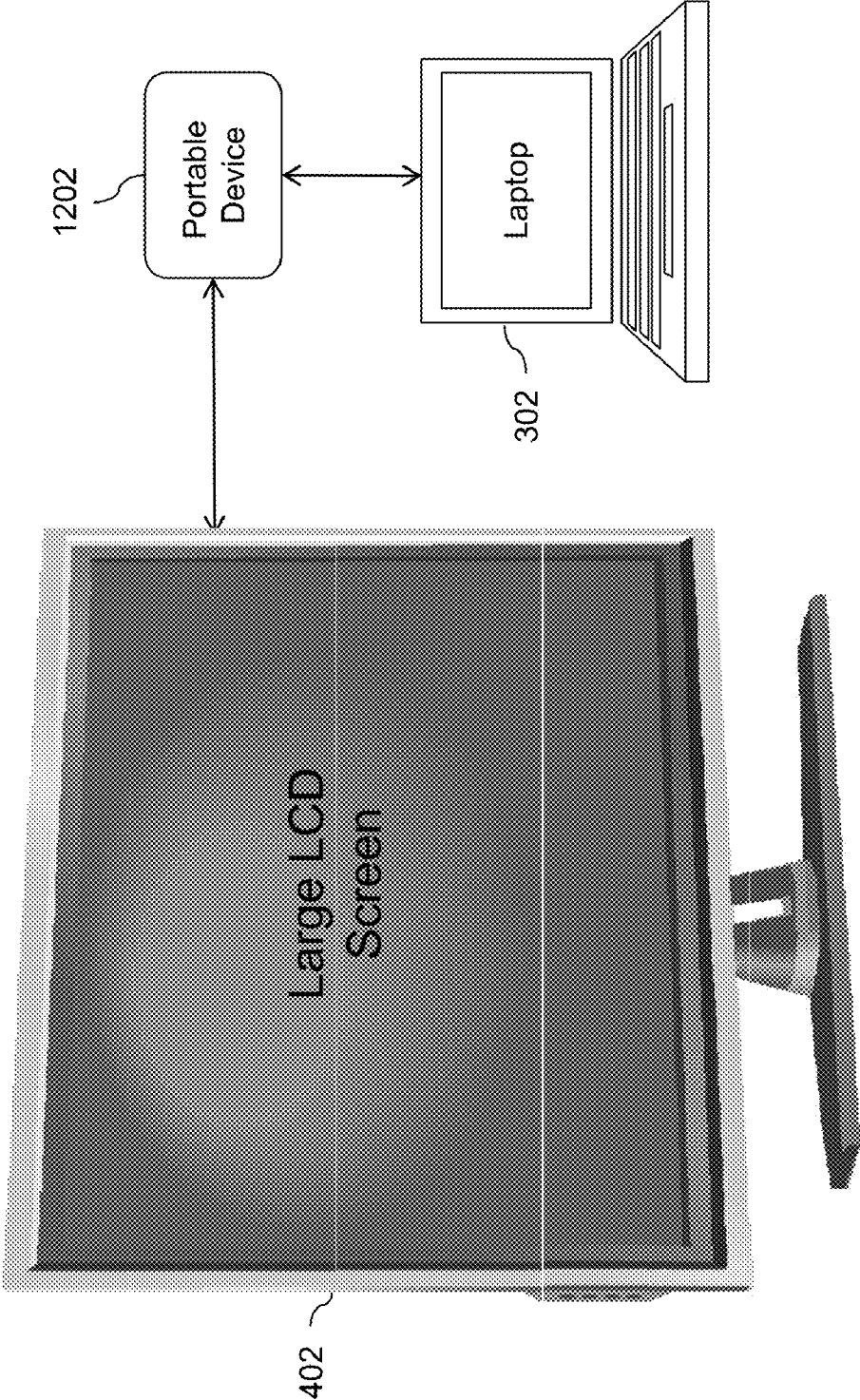

FIG. 21

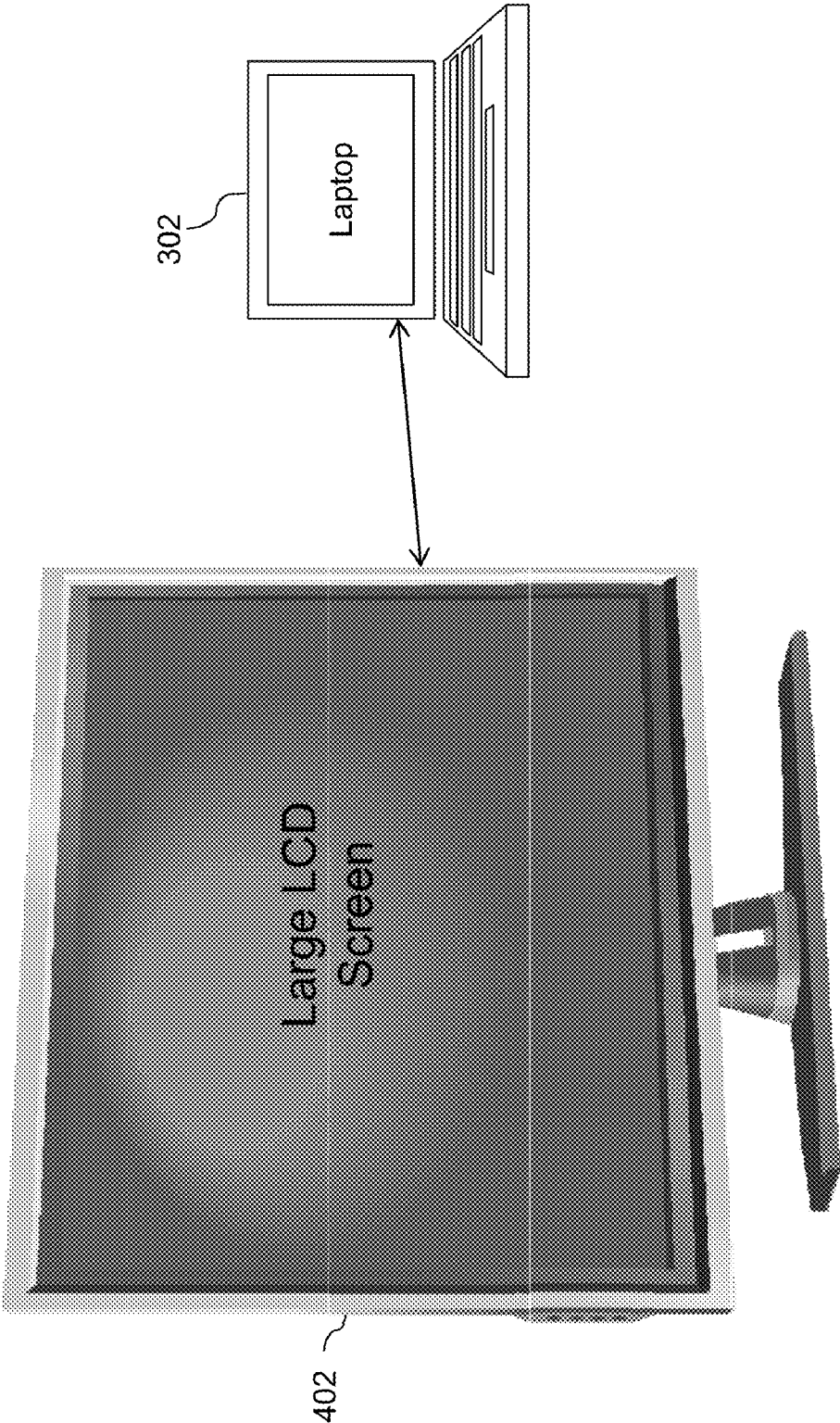

FIG. 22

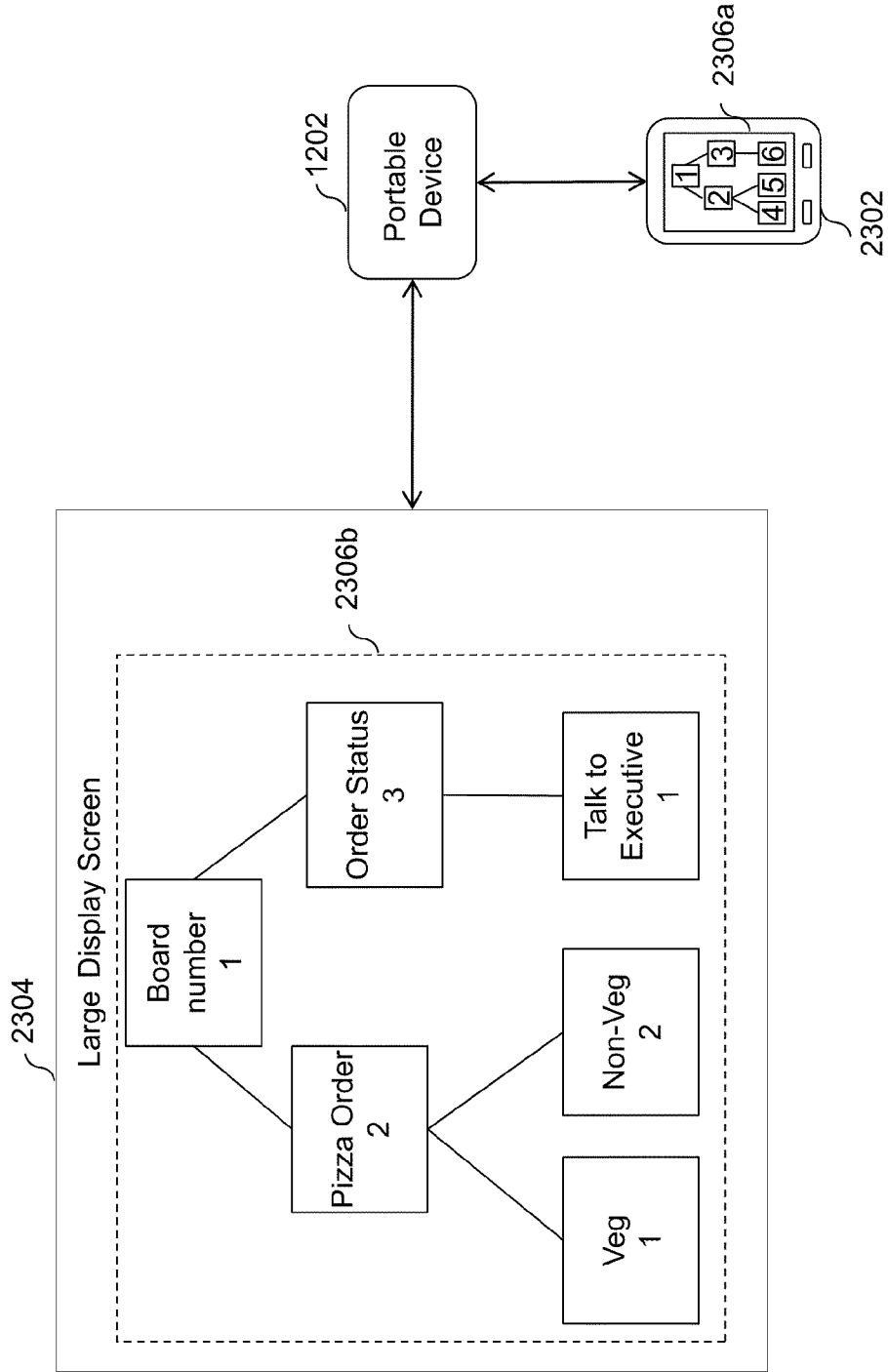

FIG. 23

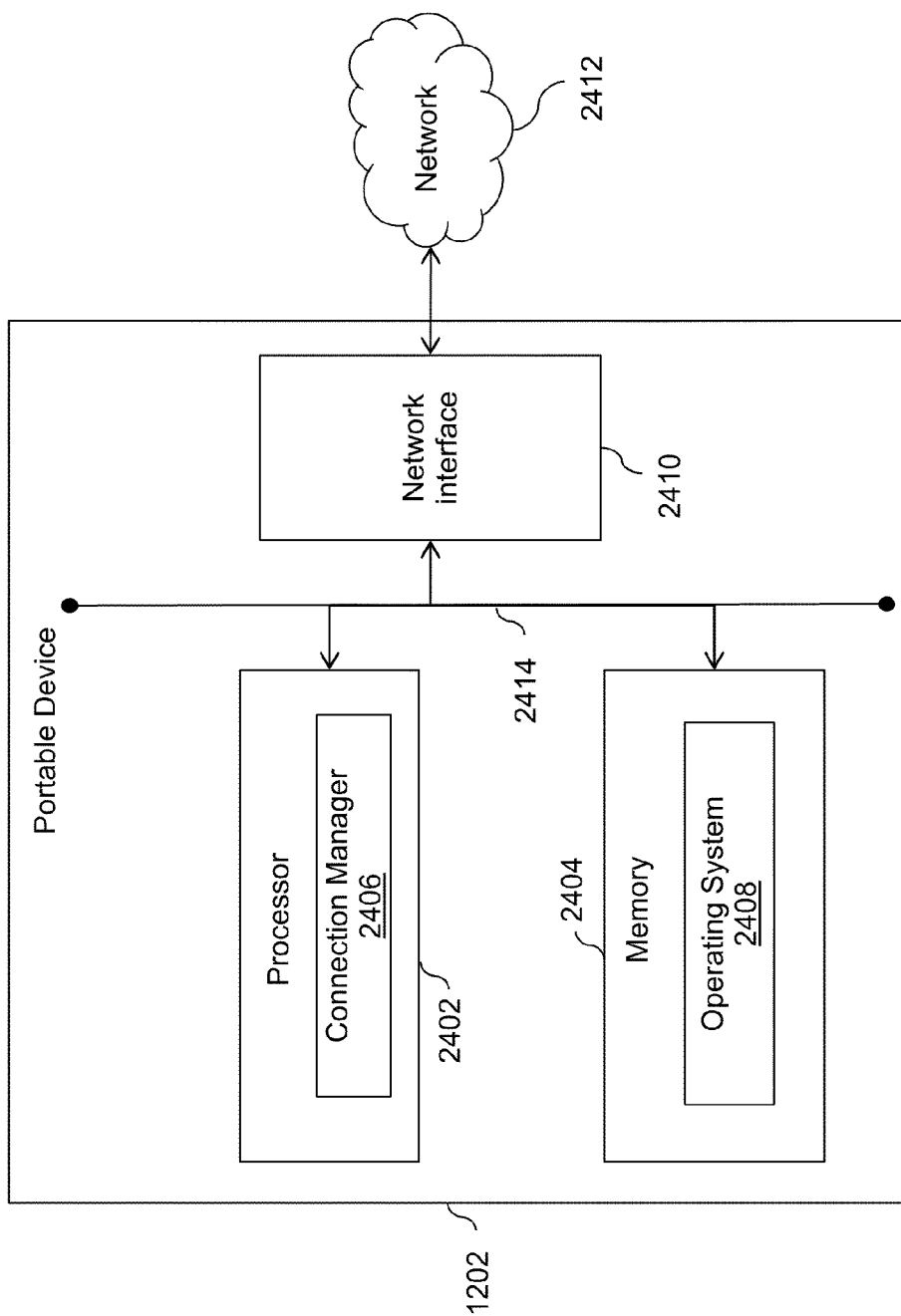

FIG. 24

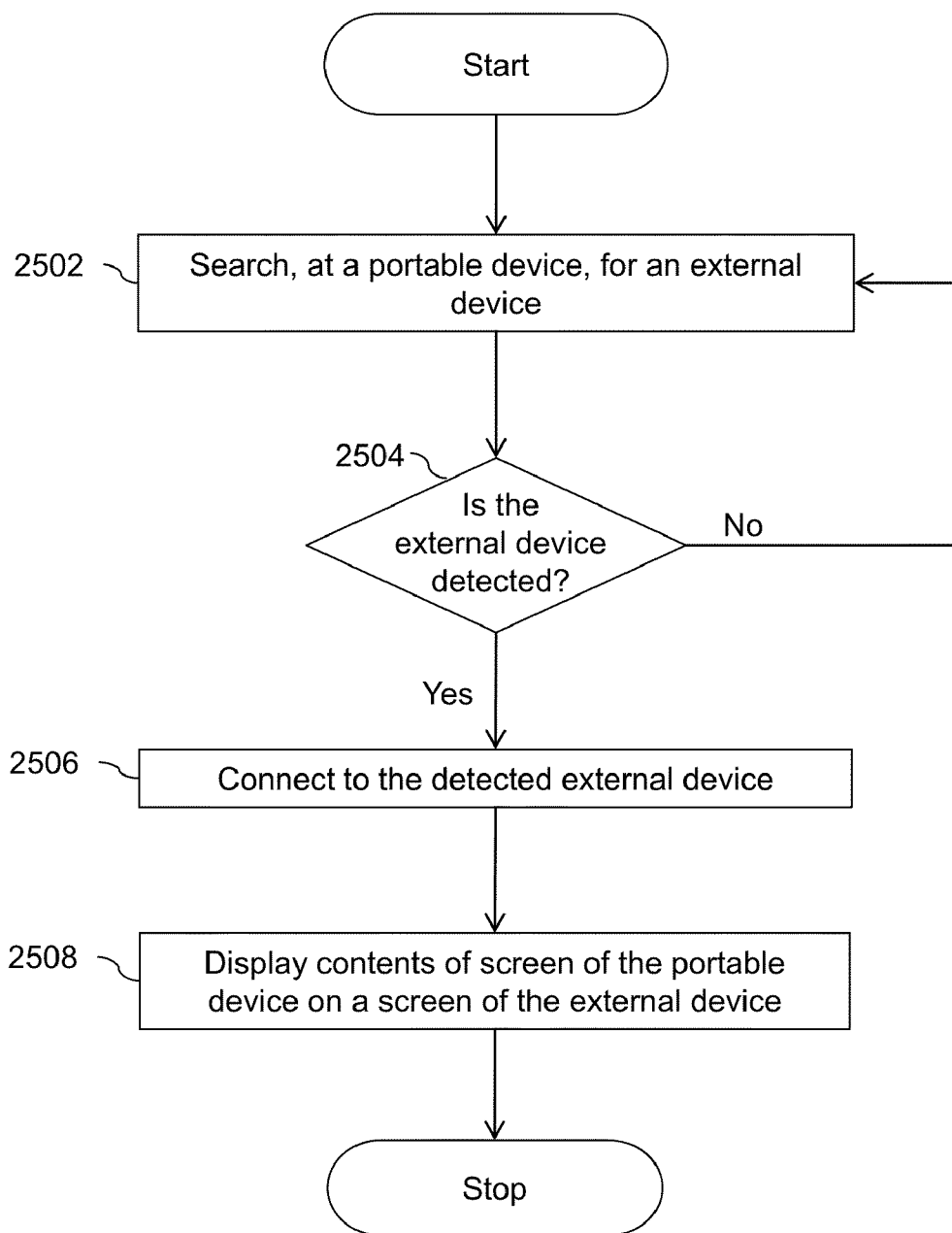

FIG. 25

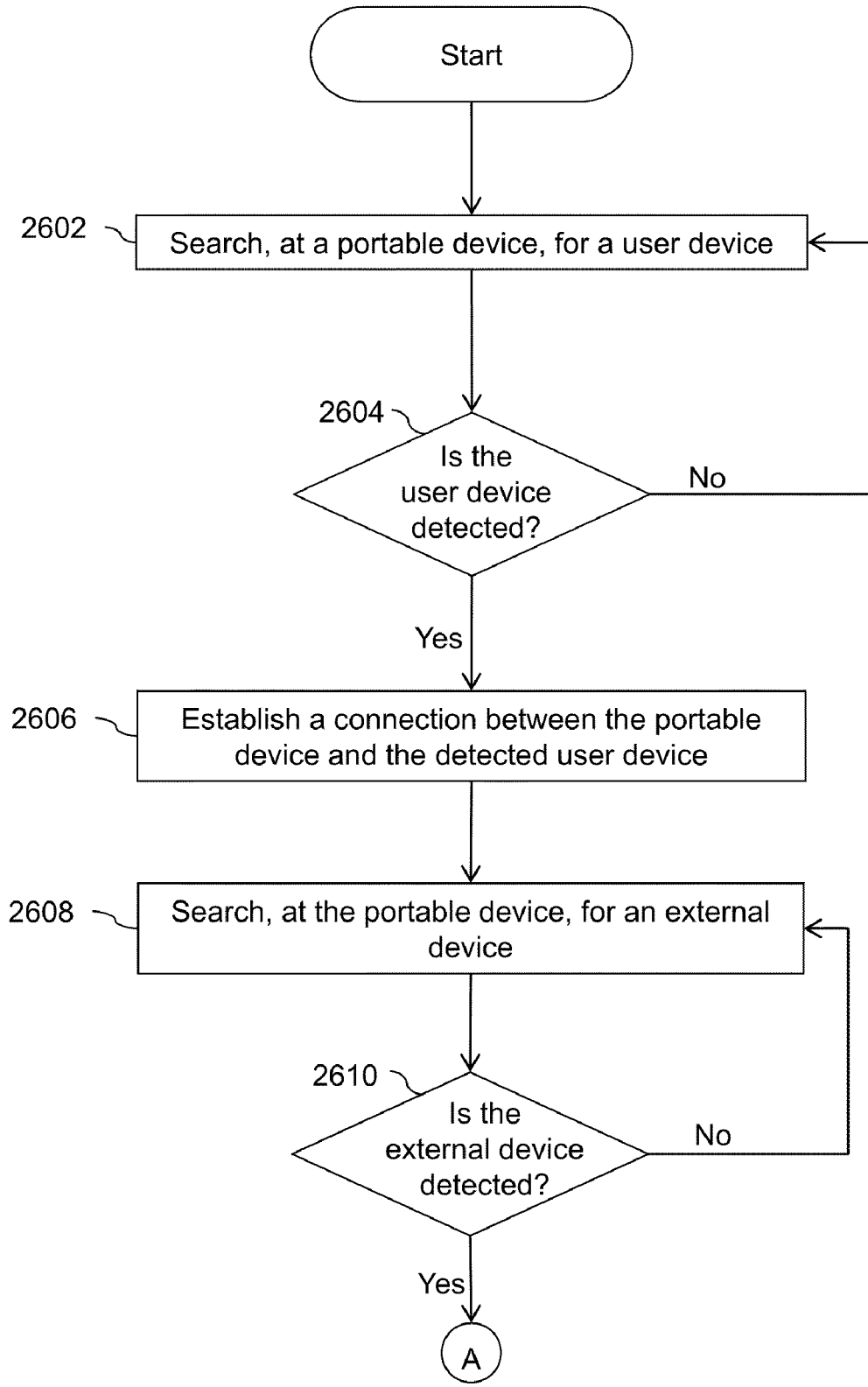

FIG. 26A

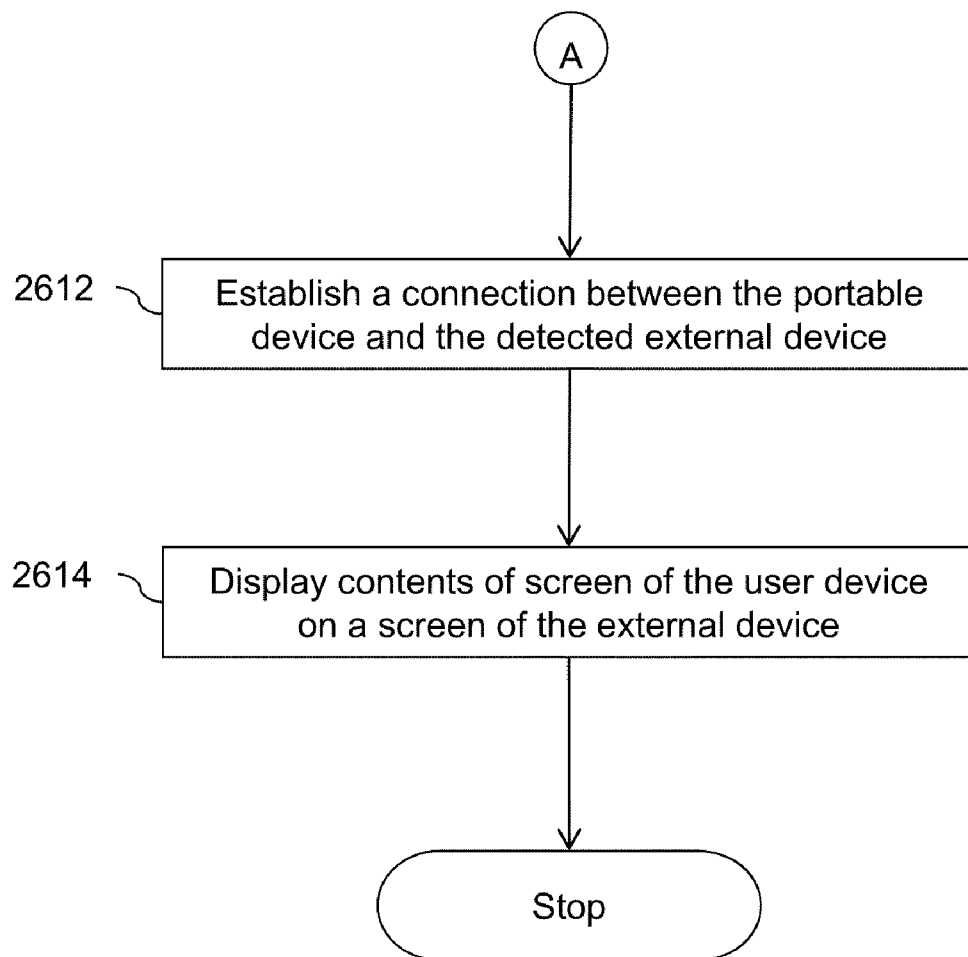

FIG. 26B

PORTABLE UNIVERSAL COMMUNICATION DEVICE

CROSS REFERENCE TO RELATED APPLICATIONS

[0001] This application is a Continuation-In-Part (CIP) of U.S. Non-Provisional application Ser. No. 12/699,618 entitled ‘Systems and methods for visual presentation and selection of IVR menu’ and filed on Feb. 3, 2010.

FIELD OF THE INVENTION

[0002] The invention relates to communication systems and more specifically the invention relates to devices and methods for enabling communication of a device with other devices.

BACKGROUND OF THE INVENTION

[0003] Various portable devices such as mobile phones are used for communication over the Internet and phone network. Further, such devices enable a user to view, read and write text, video, graphics and so forth by using their display screens. For example, the user can read and write messages, compose emails, and so forth. In recent years, the technology of the portable devices has improved tremendously. Various portable devices, such as smart phones include various hardware and software features that are generally present in personal computers. For example, various powerful mobile phone Operating Systems (OS) are available such as Windows Mobile, Apple iOS, Android, Symbian, BlackBerry OS and so forth. Therefore, the devices provide all the essential functionalities for a day to day usage for the user. However, the devices have a drawback in terms of the size of the display screens. Generally, the form factor of the portable device is such that it is easier to carry and handle by the user. As a result, the size of the keypad and display screen is also limited, which makes the use of display difficult for the user. For example, the user may be required to zoom webpages to read them on the display screen of the portable device. Further, longer viewing on a small display screen may be stressful for the user. Moreover, the use of keypad may be uncomfortable for longer usage such as typing documents with hundreds of words.

[0004] A technique disclosed in U.S. Pat. No. 5,880,732 assigned to Telefonaktiebolaget L M Ericsson publ., enables transmission of numeric or text data from display of a mobile telephone to a larger screen of a remote display monitor. However, this technique does not mention transmission of graphics to the remote display monitor. As a result, the display of the mobile telephone cannot be replicated on the remote display monitor.

[0005] Another technique is discussed in U.S. Patent Application Publication No. 2010/0216508 assigned to Augusta Technology Inc. This technique discusses driving an external display device using a mobile phone device. The audio and video content on the mobile phone can be merged and displayed on an external device connected to the mobile phone device. However, the technique is limited to replicating and controlling the contents on the mobile device.

[0006] U.S. Pat. No. 6,228,921 discloses an external keyboard that can be connected to a mobile device. However, the functionality of the keyboard is limited to the mobile phone and cannot be used on other devices that are connected to the mobile device.

[0007] In light of the above discussion, techniques are desired for connecting and driving external devices from a portable device.

SUMMARY

[0008] Embodiments of the invention provide a portable device comprising at least one processor. The portable device also comprises a memory coupled to the processor comprising data. Further, the portable device comprises a detector configured to detect at least one external device. The at least one external device is configured to connect to the portable device. Further, the portable device comprises an interface to connect to the at least one external device. The interface is configured to transmit or receive one or more control signals excluding the data. Furthermore, the portable device comprises a controller configured to enable controlling of the portable device from the at least one external device; and controlling of the at least one external device from the portable device through the interface.

[0009] Embodiments of the invention provide a method for enabling communication among a plurality of devices. The method comprises detecting, at a portable device, at least one external device configured to connect to the portable device. The method also comprises connecting with the detected at least one external device. Further the method comprises transceiving one or more control signals excluding the data. Furthermore, the method comprises controlling at least one of the portable device from the at least one external device; and at least one external device from the portable device through the interface.

[0010] An aspect of the invention is to connect a user device with limited display capability with an external device comprising a large display screen via a portable device. For example connecting a mobile phone to a laptop computer.

[0011] Another aspect of the invention connects a portable device with an external device. The connected external device is configured to display content of a screen of the portable device at the external device.

BRIEF DESCRIPTION OF THE DRAWINGS

[0012] Having thus described the invention in general terms, reference will now be made to the accompanying drawings, which are not necessarily drawn to scale, and wherein:

[0013] FIG. 1 illustrates an environment where an embodiment of the invention may function;

[0014] FIG. 2 illustrates exemplary functioning of the portable device in the environment of FIG. 1, in accordance with an embodiment of the invention;

[0015] FIG. 3 illustrates exemplary functioning of the portable device such as a smart phone in the environment of FIG. 1, in accordance with an embodiment of the invention;

[0016] FIG. 4 illustrates exemplary functioning of the portable device such as the smart phone connected to a large display screen, in accordance with another embodiment of the invention;

[0017] FIG. 5 illustrates exemplary functioning of the portable device such as the smart phone connected to a television, in accordance with another embodiment of the invention;

[0018] FIG. 6 illustrates exemplary functioning of the portable device such as the smart phone connected to the picture frame, in accordance with another embodiment of the invention;

[0019] FIG. 7 illustrates exemplary functioning of the portable device such as the smart phone connected to a Global Positioning System (GPS) navigation system, in accordance with another embodiment of the invention;

[0020] FIG. 8 illustrates exemplary functioning of the portable device such as the smart phone connected to a projector, in accordance with yet another embodiment of the invention;

[0021] FIG. 9 illustrates exemplary display of an Interactive Visual Response (IVR) menu on a large display screen connected to a portable device such as the smart phone, in accordance with an embodiment of the invention;

[0022] FIG. 10 illustrates block diagram of the portable device, in accordance with an embodiment of the invention;

[0023] FIG. 11 illustrates block diagram of the portable device, in accordance with another embodiment of the invention function;

[0024] FIG. 12 illustrates another environment where various embodiments of the invention may function;

[0025] FIG. 13 illustrates yet another environment where various embodiments of the invention may function;

[0026] FIG. 14 illustrates exemplary functioning of the portable device connected to a mobile phone and a computer in the environment of FIG. 12 or FIG. 13, in accordance with an embodiment of the invention

[0027] FIG. 15 illustrates exemplary functioning of the portable device connected to a mobile phone and a projector in the environment of FIG. 12 or FIG. 13, in accordance with another embodiment of the invention;

[0028] FIG. 16 illustrates exemplary functioning of the portable device connected to a mobile phone and large screen in the environment of FIG. 12 or FIG. 13, in accordance with another embodiment of the invention;

[0029] FIG. 17 illustrates exemplary functioning of the portable device connected to a mobile phone and a television in the environment of FIG. 12 or FIG. 13, in accordance with another embodiment of the invention;

[0030] FIG. 18 illustrates exemplary functioning of the portable device connected to a mobile phone and a laptop in the environment of FIG. 12 or FIG. 13, in accordance with another embodiment of the invention;

[0031] FIG. 19 illustrates exemplary functioning of the portable device connected to a landline phone and a telephone in the environment of FIG. 12 or FIG. 13, in accordance with another embodiment of the invention;

[0032] FIG. 20 illustrates exemplary functioning of the portable device connected to a mobile phone and a GPS navigation system, in accordance with an embodiment of the invention.

[0033] FIG. 21 illustrates an exemplary functioning of portable device connected to a large screen and laptop, in accordance with an embodiment of the invention.

[0034] FIG. 22 illustrates an exemplary functioning of portable device such as laptop connected to a large screen, in accordance with an exemplary embodiment of the invention.

[0035] FIG. 23 illustrates an exemplary display of a visual Interactive Visual Response (IVR) menu on a large display screen connected to a portable device such as the smart phone, in accordance with an embodiment of the invention;

[0036] FIG. 24 illustrates a block diagram of the portable device, in accordance with the another embodiment of the invention;

[0037] FIG. 25 is a flow diagram illustrating the functioning of portable device 102 in accordance with an embodiment of the invention; and

[0038] FIGS. 26A and 26B is a flow diagram illustrating the functioning of portable device 102 in accordance with another embodiment of the invention.

DETAILED DESCRIPTION OF THE INVENTION

[0039] Illustrative embodiments of the invention now will be described more fully hereinafter with reference to the accompanying drawings, in which some, but not all embodiments of the invention are shown. Indeed, the invention may be embodied in many different forms and should not be construed as limited to the embodiments set forth herein; rather, these embodiments are provided so that this disclosure will satisfy applicable legal requirements. Like numbers refer to like elements throughout.

[0040] FIG. 1 illustrates an environment 100 where various embodiment of the invention can function. As shown, environment 100 includes a portable device 102 that can be used by a user. Examples of portable device 102 include but are not limited to a mobile phone, a smart phone, a Personal Desktop Assistant (PDA), a tablet Personal Computer (PC), and so forth. Portable device 102 may be used for communication such as data and voice communications over a Public Switched Telephone Network (PSTN), mobile network, the Internet, the Ethernet, and so forth. In an embodiment of the invention, portable device 102 may include an Operating System (OS) such as, but not limited to, Windows Mobile, Apple iOS, Google Android, Symbian, and so forth. Portable device 102 is further configured to detect and connect to a plurality of external devices 106a-n. Portable device 102 may be connected to the plurality of external devices 106a-n. Examples of external devices 106a-n include, but are not limited to, a display screen, a keyboard, a mouse, and so forth.

[0041] Portable device 102 may connect to external devices 106a-n by using Bluetooth, Wi-Fi, Infrared, or other wireless protocols. In an embodiment, portable device 102 may include a detector for detecting at least one external device of external devices 106a-n. The detector may be hardware, an application stored as software, a firmware on portable device 102, or a combination thereof. In another embodiment of the invention, portable device 102 may include an interface to connect to the at least one external device. The interface is also configured to transmit or receive one or more control signals excluding the data. In an embodiment, the interface can be hardware such as a Universal Serial Bus (USB) docket or a software application such as a user interface.

[0042] Further, portable device 102 may connect to external devices 106a-n by using an Ethernet cable, a video cable, Universal Serial Bus (USB), and so forth. After establishing a connection between portable device 102 and external device 106a, the display on the screen of portable device 102 can be presented on external device 106a such as a display screen. Moreover, external device 106b such as a mouse connected to portable device 102, can be used to provide inputs that are reflected on the display screen of the connected external device 106. As a result, portable device 102 acts as a universal communication hub that can enable interaction of multiple external device 106a-n among each other.

[0043] Portable device 102 is further configured to transmit to or receive one or more control signals excluding data. In an embodiment, the control signals are received from at least one external device of the plurality of external devices 106a-n connected to portable device 102. In an embodiment, the one or more control signals are signals for controlling mouse events. In another embodiment of the invention, the one or

more control signals are signals for controlling one or more key presses at a keypad. In yet another embodiment, the one or more control signals are the signals for displaying content at the at least one external device. The content is not stored at the at least one external device. In another embodiment of the invention, the one or more control signals are the signals for displaying content of portable device 102. The displayed content is stored at portable device 102 and not transferred or stored at the at least one external device. In an embodiment, portable device may include a controller configured to enable controlling of portable device 102 from the at least one external device (connected external device); and controlling of the at least one external device from portable device 102 through the interface. The controller may be hardware, an application stored as software, a firmware on portable device 102, or a combination thereof.

[0044] Further, portable device 102 includes a Visuphone 104 configured to display a visual Interactive Voice Response (IVR) menu at screen of portable device 102. Further, portable device 102 stores a plurality of visual IVR menus corresponding to one or more phone numbers associated with the dialed destination or calling parties. When a call is received at portable device 102, Visuphone 104 can search for a visual IVR menu corresponding to the received phone number in a database at portable device 102. Thereafter, Visuphone 104 can display the visual IVR menu at the screen of portable device 102.

[0045] FIG. 2 illustrates exemplary functioning of portable device 102 such as a portable device 102a in the environment discussed in conjunction with FIG. 1, in accordance with an embodiment of the invention. As shown, a display screen 202, a keyboard 204, and a mouse 206 can be connected through portable device 102a. Therefore, the screen of portable device 102a such as a smart phone is displayed on a larger screen of display screen 202. Moreover, a user can use keyboard 204 and mouse 206 to access the information through portable device 102a. For example, in this configuration, the user can browse the Internet by using display screen 202, keyboard 204, and mouse 206, while portable device 102a provides the Internet connectivity. Therefore, a computer other than portable device 102a may not be required by the user. As a result, the user can carry portable device 102a and use it with various external devices 106a-n as desired. In an embodiment of the invention, display screen 202 includes a television screen. In this case, the television screen may be used to display the screen of the mobile device. Therefore, when the user can use the television screen to access various functions of portable device 102a such as, but not limited to, call receiving, dialing, browsing the phonebook, typing a message, browsing the Internet and so forth. This functionality increases the comfort in using the small form factor of portable device 102a.

[0046] In an embodiment of the invention, portable device 102a such as a smart phone or mobile phone may detect and connect to a laptop 302 as shown in FIG. 3. The connection between portable device 102a (smart phone) and laptop 302 may be wired such as via a USB wire or it can be wireless such as via Bluetooth, Wi-Fi, or any other wireless connection. Thereafter, portable device 102a may use display of laptop 302. Further, laptop 302 may be used to control one or more functions of portable device 102a and vice versa. For example, user can use one or more keys of laptop 302 may be used to access phone book of the smart phone or to dial a phone number.

[0047] In an embodiment, portable device 102a i.e. smart phone may include a detector for detecting laptop 302. The detector may be hardware, an application stored as software, a firmware on portable device 102, or a combination thereof. Further, smart phone may include an interface to connect to laptop 302. The interface may also be configured to transmit or receive one or more control signals excluding the data. In an embodiment, the interface can be hardware such as a Universal Serial Bus (USB) docket or a software application. Further, smart phone may include a controller which is configured to enable controlling of smart phone from the at least one external device such as laptop 302; and controlling of the at least one external device i.e. laptop 302 from portable device through the interface. The controller may be hardware, an application stored as software, a firmware on portable device 102, or a combination thereof.

[0048] In an embodiment, the connected external devices 106a-n may be used for displaying the content of the portable device 102, but the connected external devices may not store the content. The storage of content will always remain on the portable device 102 or 102a only. For example, the user is accessing the Internet from an Internet café. If the user wants to send a picture stored in the mobile phone through an e-mail. Then, the mobile phone can directly connect to computer or computer peripherals of the café. Thereafter, the user can search and select the picture stored at the mobile phone by using the computer screen and mouse or keyboard and can attach in the e-mail. Further, for mailing the picture stored at the mobile phone, the picture is not transferred from the mobile phone to the internet café's computer. The picture can be attached directly from the mobile phone's memory and can be mailed by using the computer connected to the mobile phone. While transferring and mailing the picture, the picture is not stored at the computer of internet café. Hence, this way the picture from the mobile phone can be mailed by using the computer of the café without actually storing or transferring the picture to the computer. This feature of the portable device enhances security as the content from the portable device is never transferred or stored on the computer of café.

[0049] FIG. 4 illustrates an exemplary functioning of portable device 102a such as a smart phone connected to an external device such as a large display screen 402, in accordance with another embodiment of the invention. Further, portable device 102a may use Bluetooth, USB wire, and so forth to connect to large screen 402. The large screen 402 may be a Light Emitting Diode (LED) display screen, a Liquid Crystal Display (LCD) screen, and so forth. Usually, portable devices such as mobile phones, smart phones, wired telephones etc. have either a small display or limited display capabilities. In an embodiment, portable device 102a may include a Visuphone. Visuphone 104 may be further configured display a visual IVR menu at portable device 102a. Portable device 102a is configured to detect and connect to one or more external devices such as large screen 402. Once configured, portable device 102a can detect large display 402 and can connect to it via Bluetooth or a wired connection. In an embodiment, portable device 102a i.e. smart phone may include a detector for detecting large screen 402. The detector may be hardware, an application stored as software, a firmware on portable device 102, or a combination thereof. Further, smart phone may include an interface to connect to large screen 402. The interface may be configured to transmit or receive one or more control signals excluding the data. In an embodiment, the interface can be hardware such as a Univer-

sal Serial Bus (USB) docket or a software application. In an embodiment, portable device **102a** may connect to external devices **106a-n** using Near Field Communication (NFC) protocol. Further, when portable device **102a** is video conferencing with another portable device, the video can be displayed at large screen **402**. For example, when the smart phone is in video call with another phone, the video of the user at another phone will be displayed at large screen **402**.

[0050] Further, smart phone may include a controller which is configured to enable controlling of smart phone from large screen **402**; and controlling of large screen **402** from portable device **102a** through the interface. The controller may be hardware, an application stored as software, a firmware on portable device **102**, or a combination thereof.

[0051] FIG. 5 illustrates functioning of portable device **102a** connected to an external device such as a television **502**, in accordance with an embodiment of the invention. Visuphone **104** is configured to display an Interactive Voice Response (IVR) menu of a phone number associated with a dialed destination or a calling party at portable device **102a**. In an embodiment, portable device **102a** is configured to detect and connect to external devices **106a-n** such as television **502**. After connecting to television **502**, screen of television **502** may be used to display the screen of portable device **102a**. Therefore, when the user is connected to television **502**, screen of television **502** can be used to access various functions of portable device **102a** such as, but are not limited to, call receiving, dialing, browsing the phonebook, typing a message, browsing the Internet, and so forth. This functionality increases the comfort in using the small form factor of portable device **102a**. In an embodiment, the content of smart phone **102a** displayed at screen of television **502** is not stored at television **502**. For example, when a call is received at a smart phone from a calling party, a visual IVR menu of the calling party may be displayed at the screen of television **502**. So, the user can see the visual IVR menu at a big screen of television and can interact with the visual menu accordingly.

[0052] In an embodiment, portable device **102a** may include a detector for detecting television screen **502**. The detector may be hardware, an application stored as software, a firmware on portable device **102**, or a combination thereof. Further, portable device **102a** may include an interface to connect to television screen **502**. The interface is configured to transmit or receive one or more control signals excluding the data. In an embodiment, the interface can be hardware such as a Universal Serial Bus (USB) docket or a software application. Further, portable device **102a** may include a controller which is configured to enable controlling of portable device **102a** from television screen **502**; and controlling of television screen **502** from portable device **102a** through the interface. The controller may be hardware, an application stored as software, a firmware on portable device **102**, or a combination thereof.

[0053] In another embodiment of the invention, portable device **102a** may detect a picture frame **602** and connect the picture frame **602** to portable device **102a** (the smart phone), as shown in FIG. 6. The connection between portable device **102a** (the smart phone) and picture frame **602** can be wireless or wired. The wireless connection may be established by using Bluetooth, Wi-Fi, NFC, and so forth. The wired connection may be established via USB or using a cable wire. In an embodiment, picture frame **602** may be a digital picture frame. The digital picture frame is a picture frame which may

be used to display images or photos without the need of printing or using them on computer. Once connected, display of picture frame **602** may be used to display content of portable device **102a**. Further, the content of smart phone **102a** is never stored at the connected external device **106a-n** such as picture frame **602**.

[0054] In another embodiment of the invention, portable device **102a** (smart phone) may detect and connect to a Global Positioning System (GPS) navigation system **702** as shown in FIG. 7. Therefore, when the user is connected to GPS navigation system **702**, screen of GPS navigation system **702** may be used for displaying content of display of portable device **102a**. Further, screen of GPS navigation system **702** can be used to access various functions of portable device **102a** such as call receiving, browsing the phonebook, browsing the Internet, and so forth. This functionality increases the comfort in using portable device **102a** such as the mobile phone which has limited display.

[0055] In an embodiment, smart phone may include a detector for detecting GPS navigation system **702**. The detector may be hardware, an application stored as software, a firmware on portable device **102**, or a combination thereof. Further, smart phone may include an interface to connect to GPS navigation system **702**. The interface is configured to transmit or receive one or more control signals excluding the data. In an embodiment, the interface can be hardware such as a Universal Serial Bus (USB) docket or a software application. Further, smart phone may include a controller which is configured to enable controlling of smart phone from GPS navigation system **702**; and controlling of GPS navigation system **702** from smart phone through the interface. The controller may be hardware, an application stored as software, a firmware on portable device **102**, or a combination thereof.

[0056] In yet another embodiment of the invention, smart phone **102a** can detect and connect to a projector **802** as shown in FIG. 8. Portable device **102a** can search for an external device **106** such as projector **802**. In an embodiment, portable device **102a** may include a detector for detecting to an external device **106** or external devices **106a-n**. The detector may be hardware, an application stored as software, a firmware on portable device **102**, or a combination thereof. Further, portable device **102a** may connect to projector **802** using any of wired or wireless connection. Further, projector **802** is configured to connect to connect to Visuphone **104** of smart phone. Further, portable device **102a** such as smart phone may include an interface to connect to projector **802**. The interface is also configured to transmit or receive one or more control signals excluding the data. Further, portable device **102a** may include a controller which is configured to enable controlling of portable device **102a** from projector **802**; and controlling of projector **802** from portable device **102a** through the interface. The controller may be hardware, an application stored as software, a firmware on portable device **102**, or a combination thereof.

[0057] Projector **802** may be connected to a display **804**. Similarly, the connection between projector **802** and display **804** can be wired or wireless. Further, projector **802** can project the display of smart phone **102a** on display **804**. Further, one or more functions of projector **802** may be controlled by using connected smart phone **102a**. Further, the content of smart phone **102a** is never stored at the connected external device **106a-n** (such as projector **802**).

[0058] FIG. 9 illustrates exemplary display of an Interactive Voice Response (IVR) menu on a large display screen 902 connected to a portable device 102a, in accordance with an embodiment of the invention. As discussed with reference to FIG. 5, Visuphone 104 is configured to display a visual IVR menu associated with a phone number of a dialed destination or a calling party at portable device 102a. Further, the visual IVR menus are stored at the portable device 102a. In an embodiment, portable device 102a can detect and connect to external devices 106a-n such as large display screen 902, configured to connect to portable device 102a. After establishing a connection with large display screen 902, Visuphone 104 can display visual IVR menu displayed at portable device 102a at large display screen 902. Large display screen 902 may be used to display content of portable device 102a, but the content is never transferred or stored at large display screen 902 (or external devices 106a-n). Large display screen 902 can be a screen of any of external devices 106a-n. Portable device 102a can be a smart phone, a mobile phone, a pager, and so forth. A visual IVR menu 904a is a visual menu including one or more options at portable device 102a. A visual IVR menu 904b is a visual menu at large display screen 902 corresponding to visual IVR menu 904a. Displaying visual IVR menu of mobile phone on large display screen 902 enhances visibility.

[0059] Further, portable device 102a may include a controller for controlling one or more functions of connected large display screen 902. The controller may be hardware, an application stored as software, a firmware on portable device 102, or a combination thereof.

[0060] FIG. 10 illustrates a block diagram of portable device 102, in accordance with an embodiment of the invention. Portable device 102 can connect to Public Switched Telephone Network (PSTN) 1016 through a radio interface 1012 in a wired or wireless manner. For example, radio interface 1012 may provide 2G, 3G, and/or 4G connectivity in case of portable device 102 being a mobile phone. Moreover, a network interface 1014 can be used to connect portable device 102 to a network 1018. Examples of network 1018 include wireless or wired networks such as Local Area Network (LAN), Personal Area Network (PAN), or other specialized networks. FIG. 11 shows when network 1018 is a wireless network 1102. Network interface 1014 may allow connectivity through various protocols such as TCP/IP, Bluetooth, acoustic signals, or other types of radio signals. For example, portable device 102 may connect to a television through Bluetooth for displaying the contents of portable device 102.

[0061] Portable device 102 includes a display 1002 to output graphical information to the user. In an embodiment of the invention, display 1002 may include a touch sensitive screen. A memory 1006 of portable device 102 stores various programs, data and/or instructions that can be executed by a processor 1004. Examples of memory 1006 include, but are not limited to, a Random Access Memory (RAM), a Read Only Memory (ROM), a hard disk, and so forth. A person skilled in the art will appreciate that other types of computer-readable media which can store data that is accessible by portable device 102, such as magnetic cassettes, flash memory cards, digital video disks, and the like, may also be used by portable device 102. Further, memory 1006 may include an OS 1010. Further, other applications such as instant messaging application, browser, and so forth may be available on portable device 102. Processor 1004 may include

a connection manager 1008 that enables portable device 102 to connect to external devices 106a-n through network interface 1014. In an embodiment of the invention, connection manager 1008 may be implemented as a second processor in portable device 102. Further, portable device 102 can transmit to or receive multiple control signals from external devices 106a-n. The multiple control signals are the signals for displaying content of portable device 102 at the connected external device such as external device 106b.

[0062] Portable device 102 includes a system bus 1020 for connecting the components. Examples of system bus 1020 include several types of bus structures including a memory bus or memory controller, a peripheral bus, or a local bus using any of a variety of bus architectures.

[0063] In an embodiment, portable device 102 may include a detector for detecting one or more external devices 106a-n. The detector may be hardware, an application stored as software, a firmware on portable device 102, or a combination thereof. Further, portable device 102 may include an interface to connect to at least one external device of external devices 106a-n. The interface is further configured to transmit or receive one or more control signals excluding the data. Further, portable device 102 may include a controller which is configured to enable controlling of portable device 102 from the at least one external device; and controlling of the at least one external device from portable device 102 through the interface. The controller may be hardware, an application stored as software, a firmware on portable device 102, or a combination thereof.

[0064] FIG. 12 illustrates another environment 1200 where various embodiments of the invention may function. As shown, environment 1200 includes portable device 1202 that can be used by a user through a user device 1204. Examples of user device 104 include but are not limited to a mobile phone, a smart phone, a Personal Desktop Assistant (PDA), a tablet Personal Computer (PC), and so forth. User device 1204 may be used for communication such as data and voice communications over a Public Switched Telephone Network (PSTN), mobile network, the Internet, the Ethernet, and so forth. User device 1204 may be connected to multiple external device 1206a-n through portable device 1202.

[0065] In an embodiment of the invention, portable device 1202 may include an Operating System (OS) such as, but not limited to, Windows Mobile, Apple iOS, Google Android, Symbian, and so forth. Examples of external devices 1206a-n include, but are not limited to, a display screen, a keyboard, a mouse, and so forth. In an embodiment of the invention, portable device 1202 may include a dock for receiving user device 1204.

[0066] In an embodiment, portable device 1202 may include a detector for detecting external devices 1206a-n such as laptop 302 or large screen 402. Further, the detector may be configured to detect user device 1204. The detector may be hardware, an application stored as software, a firmware on portable device 1202, or a combination thereof. Further, portable device 1202 may include an interface to connect to at least one external device of external devices 1206a-n. Further, the interface may be configured to connect to user device 1204. The interface is also configured to transmit or receive one or more control signals excluding the data. In an embodiment, the interface can be hardware such as a Universal Serial Bus (USB) docket or a software application. Further, portable device 1202 may include a controller which is configured to enable controlling of portable device 1202 from the at least

one external device such as laptop 302; and controlling of the at least one external device from portable device 1202 through the interface. The controller may be configured to enable controlling of portable device 1202 from user device 1204 through the interface; and to enable controlling of portable device 1202 from user device 1204. The controller may be hardware, an application stored as software, a firmware on portable device 1202, or a combination thereof.

[0067] In an embodiment, portable device 1202 may include a Visuphone 1208 that is configured to display a visual IVR menu associated with a phone number of the dialed destination or calling party. Further, portable device 1202 stores a plurality of visual IVR menus corresponding to one or more phone numbers associated with the dialed destination or calling parties. When a call is received at portable device 1202, Visuphone 1208 can search for a visual IVR menu corresponding to the received phone number in a database at portable device 1208. Thereafter, Visuphone 1208 can display the visual IVR menu at the screen of portable device 1208.

[0068] In an embodiment, portable device 1202 may detect one or more external devices 1206a-n. Further, portable device 1202 may connect to external devices 1206a-n by using an Ethernet cable, a video cable, Universal Serial Bus (USB), and so forth. Therefore, the display on the screen of user device 1204 and/or portable device 1202 can be presented on external device 1206a such as a display screen. Moreover, external device 1206b such as a mouse connected to portable device 1202 can be used to provide inputs that is reflected on the display screen. As a result, portable device 1202 acts as a universal communication hub that can enable interaction of multiple external device 1206a-n among each other and also among various user devices and external devices 1206a-n.

[0069] In an embodiment, the connected external devices may be used for displaying the content of the user device, but the connected external devices may not store the content. The storage of content will always remain on the user device only. For example, the user is accessing the internet from an external internet café. Suppose the user wants to send a picture stored in the mobile phone through an e-mail. Then, the mobile phone can directly connect to computer or computer peripherals of the café. Thereafter, the user can search and select the picture stored at the mobile phone by using the computer screen and mouse or keyboard and can attach in the e-mail. The picture is not copied to the computer memory; it always remains on mobile phone's memory. This way the picture from the mobile phone can be mailed by using the computer of the café. This feature of the portable device enhances security as the content from the user device is never transferred or stored on the computer of café.

[0070] Portable device 1202 may detect and/or connect to at least one of the plurality of external devices 1206a-n by using Bluetooth, Wi-Fi, Infrared, or other wireless protocols. Portable device 1202 is further configured to transmit to or receive one or more control signals excluding data. In an embodiment, the control signals are transmitted to or received from at least one external device of the plurality of external devices 1206a-n connected to portable device 1202. In an embodiment, the one or more control signals are signals for controlling mouse events. In another embodiment of the invention, the one or more control signals are signals for controlling one or more key presses at a keypad. In yet another embodiment, the one or more control signals are the

signals for displaying content at the at least one external device. The content is not stored at the at least one external device. In another embodiment of the invention, the one or more control signals are the signals for displaying content of portable device 1202. The displayed content is stored at portable device 1202 and not transferred or stored at the at least one external device.

[0071] In another embodiment of the invention, the one or more control signals are transmitted to or received from user device 1204 connected to portable device 1202. In another embodiment of the invention, the one or more control signals are the signals for displaying content of user device 1204 at the at least one external device. The displayed content is stored at user device 1204 and not transferred or stored at the at least one external device.

[0072] FIG. 13 illustrates yet another environment 1300 where various embodiments of the invention may function. As shown, user device 1204 may be connected to portable device 1202 via a network 1302. Network 1302 can be the Internet, LAN, MAN, and so forth. In an embodiment, user device 1204 and portable device 1202 may be separated by a large distance. Further, user device 1204 is configured to connect to portable device 1202. Further, portable device 1202 is configured to search for available one or more devices such as external devices 1206a-n and user device 1204. In an embodiment, portable device 1202 may include a detector for detecting external devices 1206a-n. The detector may be hardware, an application stored as software, a firmware on portable device 1202, or a combination thereof.

[0073] Further, portable device 1202 may include an interface to connect to at least one external device of external devices 1206a-n. Further, the interface may also be configured to connect to user device 1204. The interface is also configured to transmit or receive one or more control signals excluding the data. In an embodiment, the interface can be hardware such as a Universal Serial Bus (USB) docket or a software application. Further, portable device 1202 may include a controller which is configured to enable controlling of portable device 1202 from the at least one external device such as laptop 302; and controlling of the at least one external device from portable device 1202 through the interface. In an embodiment, the controller may also be configured to enable controlling of portable device 1202 from user device 1204 through the interface; and to enable controlling of portable device 1202 from user device 1204. The controller may be hardware, an application stored as software, a firmware on portable device 1202, or a combination thereof.

[0074] Visuphone 1208 may also display a visual IVR menu associated with a calling or dialed party or communication device. Further, the connected external device 1206a-n can display the content of the connected user device 1204 without storing the content. Moreover, the content remains at and is stored at user device 1204. Portable device 1202 can transmit or receive one or more control signals from user device 1204. Similarly, portable device 1202 can transmit or receive control signals from the at least one external device or external devices 1206a-n.

[0075] FIG. 14 illustrates exemplary functioning of portable device 1202 connected to a mobile phone 1402 and a computer in the environment as discussed in conjunction with FIG. 12 or FIG. 13. As shown, user device 1204 such as mobile phone 1402 may connect to display screen 202, keyboard 204, and mouse 206 of the computer through portable device 1202. As shown, portable device 1202 may include

Visuphone 1208 for displaying a visual IVR menu on screen 202. Therefore, after establishing connection between mobile phone 1402 and portable device 1202, the screen of mobile phone 1402 can be displayed on a larger screen of display screen 202 or monitor. Portable device 1202 can receive from or transmit one or more signals to display screen 202, keyboard 204, and mouse 206. Moreover, a user can use keyboard 204 and mouse 206 to access the information through portable device 1202. For example, in this configuration, the user can browse the Internet by using display screen 202, keyboard 204, and mouse 206, while mobile phone 1402 provides the Internet connectivity and portable device 1202 provides the connectivity among mobile phone 1402 (or user device 1204), display screen 202, keyboard 204 and mouse 206. Therefore, a computer other than mobile phone 1402 and portable device 1202 may not be required by the user. In an embodiment, mobile phone 1402 (or user device 1204) may not include a Visuphone. In an embodiment, multiple mobile phones may be configured to connect to portable device 1202. Further, user device 1204 such as mobile phone 1402 can transmit to or receive control signals from portable device 1202. Based on the control signals content of mobile phone 1402 may be displayed at display screen 202

[0076] In an embodiment of the invention, the content displayed at the external device of devices 1206a-n is not stored at the connected external device or devices 1206a-n. In another embodiment of the invention, the user may use the features or functions of the connected external devices. Further, by connecting to the external device the user at the user device can use the high computation functionality of the external device. For example, if a mobile phone do not have the internet facility than, by connecting the device to a large screen configured to connect to the internet, the user can access the internet. This may also enhance visibility of web pages on large screen. As the mobiles have a limited screen size.

[0077] In an embodiment of the invention, portable device 1202 can provide connectivity to multiple user devices. For example, in a home environment, portable device 1202 may detect multiple mobile phones and wired phone. Therefore, the screen of a mobile phone may be displayed on a television near to that mobile phone. In another embodiment of the invention, portable device 1202 may enable communication among multiple user devices. Further, the multiple user devices are configured to connect to portable device 1202.

[0078] In an embodiment, portable device 1202 may include a detector for detecting external devices 1206a-n such as a computer. Further, the detector may be configured to detect user device 1204 such as mobile phone 1402. The detector may be hardware, an application stored as software, a firmware on portable device 1202, or a combination thereof. Further, portable device 1202 may include an interface to connect to at least one external device of external devices 1206a-n. Further, the interface may be configured to connect to mobile phone 1402. The interface is configured to transmit or receive one or more control signals excluding the data from at least one of mobile phone 1402 and the at least one external device. In an embodiment, the interface can be hardware such as a Universal Serial Bus (USB) docket or a software application. Further, portable device 1202 may include a controller which is configured to enable controlling of portable device 1202 from the at least one external device such as a computer; and controlling of the at least one external device from portable device 1202 through the interface. The controller may

be configured to enable controlling of portable device 1202 from the at least one external device through the interface; and to enable controlling of portable device 1202 from the connected at least one external device. The controller may be hardware, an application stored as software, a firmware on portable device 1202, or a combination thereof.

[0079] FIG. 15 illustrates exemplary functioning of portable device 1202 connected to mobile phone 1402 and a projector 1502 in the environment as discussed in conjunction with FIG. 12 or FIG. 13. Portable device 1202 may be connected to projector 1502, and to a user device such as mobile phone 1402. Further, projector 1502 may be connected to a bigger display 1504. Once all the devices are connected, display of mobile phone 1402 may be displayed on bigger display screen 1504. Further, portable device 1202 may exchange one or more control signals with projector 1502 and mobile phone 1402. Portable device 1202 is configured to detect and connect to the configured devices i.e. mobile phone 1402 (or user device) and projector 1502. Thereafter, one or more functions of mobile phone 1502 can be controlled by using projector 1502 and vice versa. Further, a display of content of mobile phone 1402 may be produced at display 1504 connected to projector 1502.

[0080] FIG. 16 illustrates exemplary functioning of portable device 1202 connected to mobile phone 1402 and large screen 402 in environment 1200, in accordance with an embodiment of the invention. As shown, portable device 1202 may detect an external device such as a large screen 402. A user device such as a mobile phone 1402 can be connected to large screen 402 via portable device 1202. Mobile phone 1402 is configured to connect with portable device 1202. Similarly, large screen 402 is also configured to connect to portable device 1202. Further, portable device 1202 can exchange a plurality of control signals with mobile phone 1402 and/or large screen 402. In an embodiment, the plurality of control signals may be signals to display content of a screen of user device such as mobile phone 1402. Further, the connection between portable device 1202 and mobile phone 1402 can be wired or wireless. Furthermore, the connection between portable device 1202 and large screen 402 can be wired or wireless. Thereafter, display of mobile phone 1402 may be displayed on large screen 402 after being connected to portable device 1202.

[0081] In an embodiment of the invention, external device 1206a-n such as a television 502 may be connected to user device such as mobile phone 1402 via portable device 1202 as shown in FIG. 17. Further, mobile phone 1402 and television 502 are configured to connect with portable device 1202. In an embodiment of the invention, mobile phone 1402 may include a Visuphone. Though not shown, any user device other than mobile phone 1402 may be connected to portable device 1202. Further, when connected to television 502, the content of mobile phone 1402 may be displayed at screen of television 502. For example, if a user receives a message at a mobile phone 1402, then the message will be displayed at television 502. Further, usually mobile phone 1402 has limited display capabilities. By connecting the mobile phone with television, the display of contents of mobile phone 1402 can be enhanced. For example, when a call is received from a service provider implementing an Interactive Voice Response (IVR) system, then a visual menu will be displayed at the screen of television 502. Further, if the visual menu has many options then the visual menu may be displayed as two or more

pages or screens on the external device 1206. The user can move from one screen to another by dragging.

[0082] FIG. 18 illustrates exemplary functioning of portable device 1202 connected to mobile phone 1402 and laptop 302 in the environment of FIG. 12 or FIG. 13, in accordance with another embodiment of the invention. A communication session between mobile phone 1402 and laptop 302 may be established via portable device 1202. Mobile phone 1402 is configured to connect with portable device 1202. Similarly, laptop 302 is also configured to connect to portable device 1202. After getting connected to each other via portable device 1202 contents of mobile phone 1402 may be displayed on screen of laptop 302.

[0083] In an embodiment, portable device 1202 may include a detector for detecting laptop 302. Further, the detector may be configured to detect a user device 1204 such as mobile phone 1402. The detector may be hardware, an application stored as software, a firmware on portable device 1202, or a combination thereof. Further, portable device 1202 may include an interface to connect to laptop 302. Further, the interface may be configured to connect to mobile phone 1402. The interface is configured to transmit or receive one or more control signals excluding the data. In an embodiment, the interface can be hardware such as a Universal Serial Bus (USB) docket or a software application. Further, portable device 1202 may include a controller which is configured to enable controlling of portable device 1202 from the laptop 302; and controlling of laptop 302 from portable device 1202 through the interface. The controller may be configured to enable controlling of portable device 1202 from mobile phone 1402 through the interface; and to enable controlling of portable device 1202 from mobile phone 1402. The controller may be hardware, an application stored as software, a firmware on portable device 1202, or a combination thereof.

[0084] FIG. 19 illustrates exemplary functioning of portable device 1202 connected to a picture frame 602 and a telephone 1902 in the environment of FIG. 12 and FIG. 13, in accordance with another embodiment of the invention. Picture frame 602 may be connected to a user device such as a wired telephone 1902 via portable device 1202 as shown in FIG. 19. As shown, portable device 1202 may detect an external device such as wired telephone 1902 and connect to it. Further, portable device 1202 may detect and connect to an external device such as picture frame 602. Portable device can transmit to or receive control signals to and from mobile phone 1402 and/or picture frame 602. A display of content of a screen of telephone 1902 may be displayed at picture frame 602 based on control signals.

[0085] According to yet another embodiment of the invention, external device such as a GPS navigation system 702 may be connected to a user device such as mobile phone 1402 via portable device 1202 as shown in FIG. 20. Both the devices i.e. GPS navigation system 702 and mobile phone 1402 are configured to connect to portable device 1202. Once connected to portable device 1202, contents of mobile phone 1402 may be displayed by using screen of GPS navigation system 702. For example, when a call is received at mobile phone 1402, an IVR menu associated with the calling party may be displayed at screen of GPS navigation system 702.

[0086] FIG. 21 illustrates an exemplary functioning of portable device 1202 connected to large screen 402 and laptop 302 in the environment of FIG. 12 and FIG. 13. As shown in FIG. 21, a connection may be established between laptop 302 and large screen 402 via portable device 1202. The connec-

tion can be wireless or wired. After establishing the connection, the content stored at laptop 302 may be displayed at large screen 402. Further, while displaying the content of laptop 302, large screen 402 may not store the content. For example, if a user wants to watch a movie stored at laptop, he/she can do by connecting the laptop to the portable device (via wireless or wired connection). This way large screen 302 can display movie without storing or saving movie in or at large screen 402. Further, portable device 1202 can include an interface to transmit to or receive multiple control signals from external devices 1206a-n such as large screen 302. The multiple control signals are the signals for displaying content of user device 1204 at the connected external device such as external device 1206b. In an embodiment, the interface can be hardware such as a Universal Serial Bus (USB) docket or a software application.

[0087] In an embodiment, laptop 302 may include a Visuphone and the connection may be established directly between laptop 302 (including Visuphone) and large screen 402 as shown in FIG. 22. In such a case the laptop 302 is configured to detect external devices and can connect to detected external device. Further, the connection may be a wireless connection or a wired connection. After connecting with large screen 402, the content stored at laptop 302 may be displayed by using large screen 402. Further, the content stored at laptop 302 such as pictures, movies, music files etc are never transferred to memory of external devices (such as large screen 402).

[0088] FIG. 23 illustrates an exemplary display of a visual Interactive Voice Response (IVR) menu on a large display screen 2304 connected to a portable device such as smart phone 2302, in accordance with an embodiment of the invention. Visuphone 1208 is configured to display visual IVR menu associated with the dialed destination or the calling party at portable device 1202. Display 2306a is a display of a visual IVR menu on smart phone 2302. Display 2306b is the display of the visual IVR menu on large display screen 2302 corresponding to display 2306a of smart phone 2302. Further, the visual IVR menu may include hundreds of options and may be big enough not to fit on a single screen. In such a case the visual IVR menu can be displayed as interlinked multiple screens. And the user can switch between these multiple screens.

[0089] FIG. 24 illustrates a block diagram of portable device 1202, in accordance with an embodiment of the invention. Network interface 2410 can be used to connect portable device 1202 to network 2412. Examples of network 2412 include wireless or wired networks such as Local Area Network (LAN), Personal Area Network (PAN), Bluetooth, or other specialized networks. A network interface 2410 may allow connectivity through various protocols such as TCP/IP, Bluetooth, acoustic signals, or other types of radio signals. For example, portable device 1202 may connect a mobile phone to a television through a Bluetooth communication link. As a result, the contents on screen of the mobile phone can be displayed on the television screen which is larger than that of the mobile phone. In an embodiment of the invention, portable device 1202 can use different protocols for communicating with different devices based on their capabilities. For example, portable device 1202 may connect to a mobile phone through Bluetooth and the television through Wi-Fi.

[0090] Portable device 1202 includes a memory 2404 to store various programs, data and/or instructions that can be executed by a processor 2402. Examples of memory 2404

include, but are not limited to, a Random Access Memory (RAM), a Read Only Memory (ROM), a hard disk, and so forth. A person skilled in the art will appreciate that other types of computer-readable media which can store data that is accessible by portable device 1202, such as magnetic cassettes, flash memory cards, digital video disks, and the like, may also be used by portable device 1202. Memory 2404 may include an OS 2408. Further, other applications such as instant messaging application, browser, and so forth may be available on portable device 1202. Processor 2402 may include a connection manager 2406 that enables portable device 1202 to connect to external devices 1206a-n through network interface 2410. In an embodiment of the invention, connection manager 2406 may be implemented as a second processor in portable device 1202.

[0091] Portable device 1202 includes a system bus 2414 for connecting the components. Examples of system bus 2414 include several types of bus structures including a memory bus or memory controller, a peripheral bus, or a local bus using any of a variety of bus architectures.

[0092] In an embodiment, portable device 1202 may include a detector for detecting one or more external devices 1206a-n. Further, the detector is also configured to detect user device 1204. The detector may be hardware, an application stored as software, a firmware on portable device 1202, or a combination thereof. Portable device 1202 may also include an interface for connecting to the one or more external device 1206a-n. The interface is also configured to connect to user device 1204. The interface can also transmit to and receive one or more control signals from user device 1204 and connected external devices 1206a-n. In an embodiment, the interface can be hardware such as a Universal Serial Bus (USB) docket or a software application. Portable device 1202 may also include a controller for controlling the connected devices such as user device 1204 and external devices 1206a-n. The controller can also enable controlling of portable device 1202 from user device 1204 and the connected external devices 1206a-n. The controller may be hardware, an application stored as software, a firmware on portable device 1202, or a combination thereof.

[0093] FIG. 25 is a flow diagram illustrating the functioning of portable device 102 in accordance with an embodiment of the invention. As discussed with reference to FIG. 1, portable device 102 includes Visuphone 104 configured to display a visual IVR menu at portable device 102. Further, portable device 102 is configured to detect and connect to any one of external devices 106a-n.

[0094] At step 2502, portable device 102 searches for an external device 106 which is configured to connect to portable device 102. For example, a detector present in a smart phone can search for an external device such a large display screen, a laptop, a computer, and so forth. The detector may be hardware, an application stored as software, a firmware on portable device 102, or a combination thereof. At step 2504, it is checked whether the external device is available. In an embodiment, the availability of external device is checked within a predefined distance such as within 50 meters, 10 meters, and so forth. If the external device is detected, portable device 1202 connects to the external device at step 2506, else control goes back to step 2502. Portable device 1202 includes an interface for connecting to the external device. Further, the interface can transmit or receive one or more control signals from the external device. In an embodiment,

the interface can be hardware such as a Universal Serial Bus (USB) docket or a software application.

[0095] Thereafter, at step 2508 contents of display screen of portable device 1202 are displayed at the connected external device based on the control signals. For example, when connected to a laptop, the content of smart phone is displayed on the laptop screen. Portable device 1202 may also include a controller for enabling controlling of portable device from the connected external device and vice versa. The controller may be hardware, an application stored as software, a firmware on portable device 102, or a combination thereof.

[0096] FIGS. 26A and 26B is a flow diagram illustrating the functioning of portable device 1202 in the environment 1200, in accordance with another embodiment of the invention. Portable device 1202 includes a Visuphone 1208 for displaying a visual IVR menu associated with phone number of dialed destination or calling party. Portable device 1202 is configured to detect and connect to one or more devices such as external devices 1206a-n, user device 1204, and so forth.

[0097] At step 2602, portable device 1202 searches for a user device 1204. At step 2604, it is checked whether user device 1204 is available. A detector at portable device searches and detects user device 1204. The detector may be hardware, an application stored as software, a firmware on portable device 1202, or a combination thereof. If user device 1204 is available then a connection is established between portable device 1202 and detected user device 1204 at step 2606 else control goes back to step 2602.

[0098] At step 2608, portable device 1202 searches for an external device. At step 2610, it is checked whether the external device 1206 such as external device 1206b is available. The detector of portable device 1202 may search and detect an external device. If external device 1206 is available, then the process control goes to step 2612 else the control goes back to step 2608. At step 2612, a connection is established between portable device 1202 and the detected external device 1206b. Portable device 1202 includes an interface configured to connect to detected external device 1206b. The interface is also configured to transmit or receive one or more control signals from user device 1204 and the connected external device 1206b. In an embodiment, the interface can be hardware such as a Universal Serial Bus (USB) docket or a software application. Thereafter, contents of display of connected user device 1204 are displayed on a screen of the connected external device 1206b. In an embodiment of the invention, the content is displayed at the connected external device 1206b based on the one or more control signals. For example, contents of a mobile phone may be displayed on a screen of a television which is connected to the television via portable device 1202. Portable device 1202 may also include a controller for enabling controlling of portable device from at least one of user device and connected external device and vice versa. The controller may be hardware, an application stored as software, a firmware on portable device 1202, or a combination thereof.

1. A portable device comprising:
 - at least one processor;
 - a memory coupled to the processor comprising data;
 - a detector configured to detect at least one external device, wherein the at least one external device is configured to connect to the portable device;
 - an interface to connect to the at least one external device, wherein the interface is configured to transmit or receive one or more control signals excluding the data; and

- a controller configured to enable controlling of the portable device from the at least one external device; and controlling of the at least one external device from the portable device through the interface.
- 2. The portable device of claim 1, wherein the detector is also configured to detect a user device, wherein the user device is configured to connect to the portable device.
- 3. The portable device of claim 2, wherein the interface is also configured to connect to the user device.
- 4. The portable device of claim 4, wherein the one or more control signals are transmitted to or received from at least one of the user device and the at least one external device.
- 5. The portable device of claim 4, wherein the one or more control signals are signals for controlling mouse events.
- 6. The portable device of claim 4, wherein the one or more control signals are signals for controlling one or more key presses at a keypad.
- 7. The portable device of claim 4, wherein the one or more control signals are the signals for displaying content at the at least one external device, wherein the content is not stored at the at least one external device.
- 8. The portable device of claim 7, wherein the one or more control signals are the signals for displaying content of the portable device, wherein the content is stored at the portable device.
- 9. The portable device of claim 7, wherein the control signals are the signals for displaying content of the user device, wherein the content is stored at the user device.
- 10. The portable device of claim 1, wherein the memory comprises a plurality of visual Interactive Voice Response (IVR) menus associated with a plurality of phone numbers.
- 11. A method for enabling communication among a plurality of devices, the method comprising:
 - detecting, at a portable device, at least one external device configured to connect to the portable device;

- connecting with the detected at least one external device; and
- and
- transceiving one or more control signals excluding the data; and
- controlling at least one of the:
 - portable device from the at least one external device; and
 - at least one external device from the portable device through the interface.
- 12. The method of claim 11 further comprising detecting a user device, wherein the user device is configured to connect to the portable device.
- 13. The method of claim 12 further comprising connecting to the user device.
- 14. The method of claim 11, wherein the control signals are transmitted to or received from at least one of the user device and the at least one external device.
- 15. The method of claim 11, wherein the control signals are signals for controlling mouse events.
- 16. The method of claim 11, wherein the control signals are the signals for controlling one or more key presses at a keypad.
- 17. The method of claim 11, wherein the control signals are the signals for displaying content at the at least one external device, wherein the content is not stored at the at least one external device.
- 18. The method of claim 11, wherein the control signals are the signals for displaying content of the portable device, wherein the content is stored at the portable device.
- 19. The method of claim 13, wherein the control signals are the signals for displaying content of the user device, wherein the content is stored at the user device.
- 20. The method of claim 11, wherein the portable device comprises a plurality of visual Interactive Voice Response (IVR) menus.

* * * * *