



US00RE40467E

(19) **United States**
(12) **Reissued Patent**
Ryals et al.

(10) **Patent Number:** **US RE40,467 E**
(45) **Date of Reissued Patent:** **Aug. 26, 2008**

(54) **METHOD AND APPARATUS FOR MANAGING THE FLOW OF DATA WITHIN A SWITCHING DEVICE**

(75) Inventors: **Randy Ryals**, Menlo Park, CA (US);
Jeffrey Prince, Sunnyvale, CA (US); **H. Earl Ferguson**, Los Altos, CA (US);
Mike K. Noll, San Jose, CA (US);
Derek H. Pitcher, Newark, CA (US)

(73) Assignee: **Nortel Networks Limited**, St. Laurent, Quebec (CA)

(21) Appl. No.: **11/347,786**

(22) Filed: **Feb. 3, 2006**

Related U.S. Patent Documents

Reissue of:

(64) Patent No.: **6,788,671**
Issued: **Sep. 7, 2004**
Appl. No.: **10/093,290**
Filed: **Mar. 5, 2002**

U.S. Applications:

(63) Continuation of application No. 08/896,485, filed on Jul. 17, 1997, now Pat. No. 6,427,185, which is a continuation of application No. 08/536,099, filed on Sep. 29, 1995, now abandoned.

(51) **Int. Cl.**
H04L 12/00 (2006.01)

(52) **U.S. Cl.** **370/351; 370/355; 370/359**

(58) **Field of Classification Search** **370/351, 370/355, 359, 356, 357**

See application file for complete search history.

(56) **References Cited**

U.S. PATENT DOCUMENTS

4,975,695 A * 12/1990 Almond et al.
5,130,984 A * 7/1992 Cisneros
5,195,181 A * 3/1993 Bryant et al.

(Continued)

OTHER PUBLICATIONS

M.A. Henrion, et al. "Switching Network Architecture for ATM Based Broadband Communications", ISS May 27-Jun. 1, 1990, vol. V pp. 1-8.*

Edoardo Biagioni, et al. "Designing a practical ATM LAN", IEEE Network, Mar. 1993, vol. 7 No. 2.*

Anthony J. McAuley, et al. "Fast Routing Table Lookup Using CAMs" IEEE Computer Society Press, 1993, vol. 3, Los Alamitos.*

Robert J. Souza, et al. "GIGAswitch System: A High-performance Packet-switching Platform", Digital Technical Journal, vol. 6 No. 1, 1994.*

Drynan, D. and Ellis, J., "A New Class of Switch for the Multimedia Age," UMI, Inc.; ABI/INFORM, Bell Northern Research Ltd., vol. 28, No. 6; pp. 52-67; ISSN: 0040-2710, 5/94.*

(Continued)

Primary Examiner—Kenneth R. Coulter

(74) *Attorney, Agent, or Firm*—Blakely, Sokoloff, Taylor & Zafman LLP

(57) **ABSTRACT**

A method and apparatus for managing the flow of data within a switching device is provided. The switching device includes network interface cards connected to a common backplane. Each interface card is configured to support the maximum transfer rate of the backplane by maintaining a "pending" queue to track data that has been received but for which the appropriate routing destination has not yet been determined. The switching device includes a switch controller that maintains a central card/port-to-address table. When an interface card receives data with a destination address that is not known to the interface card, the interface card performs a direct memory access over a bus that is separate from the backplane to read routing data directly from the central table in the switch controller. Each interface card builds and maintains a routing information table in its own local memory that only includes a routing information for the destination addresses that the interface card is most likely to receive.

69 Claims, 4 Drawing Sheets

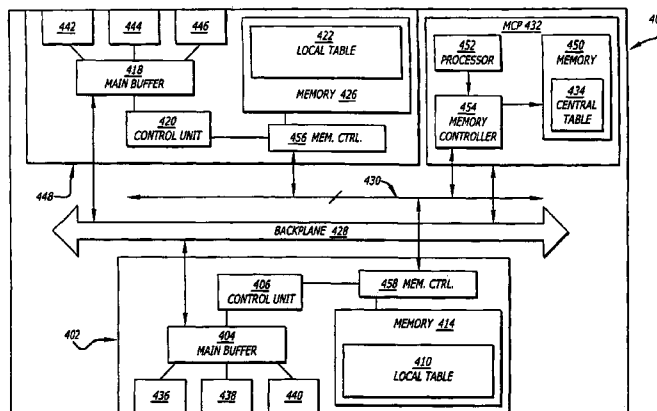

U.S. PATENT DOCUMENTS

5,214,760	A	*	5/1993	Hammond et al.	
5,386,413	A	*	1/1995	McAuley et al.	
5,394,402	A	*	2/1995	Ross	
5,408,469	A	*	4/1995	Opher et al.	
5,420,858	A	*	5/1995	Marshall et al.	
5,471,472	A	*	11/1995	McClure et al.	
5,483,640	A	*	1/1996	Isfeld et al.	
5,502,719	A	*	3/1996	Grant et al.	
5,524,113	A	*	6/1996	Gaddis	
5,537,395	A	*	7/1996	Alles et al.	
5,555,244	A	*	9/1996	Gupta et al.	
5,588,115	A	*	12/1996	Augarten	
5,592,622	A	*	1/1997	Isfeld	
5,594,734	A	*	1/1997	Worsley et al.	
5,732,080	A	*	3/1998	Ferguson et al.	370/392
5,802,278	A	*	9/1998	Isfeld	
5,809,024	A	*	9/1998	Ferguson et al.	370/395.53
5,852,606	A	*	12/1998	Prince et al.	
5,889,775	A	*	3/1999	Sawicz et al.	370/360
6,216,167	B1	*	4/2001	Momirov	709/238
6,427,185	B1	*	7/2002	Ryals et al.	711/100
7,031,296	B1	*	4/2006	Ryals et al.	370/351

OTHER PUBLICATIONS

Legible Copy of Text Portion of Reference AA, Above.*
 Tannenbaum, A., "Structured Computer Organization,"
 Third Edition, Prentice Hall, Englewood Cliffs, NJ, ISBN
 0-13-85466202, 1990, pp. 209-215.*
 Bryant, Stewart F. and Brash, David L.A., "The DECNIS
 500/600 Multiprotocol Bridge/Router and Gateway," Digital
 Technical Journal, vol. 5, No. 1, Winter 1993, pp. 84-98.*
 McAuley, Anthony J. and Francis, Paul, "Fast Routing Table
 Lookup Using CAMs," IEEE Computer Society Press, Los
 Alamitos, CA (1993), pp. 1382-1391.*
 De Prycker, Martin, "Asynchronous Transfer Mode: Solu-
 tion for Broadband ISDN," (1991), pp. 55-89, Ellis Hor-
 wood Limited, West Sussex, England.*
 McKeown, Nick; Edell, Richard and Le, My T., "The Bay
 Bridge: A High Speed Bridge/Router," IFIP PfHSN Work-
 shop, Stockholm, Sweden, May 1992, pp. 1-18.*
 Jaffe, J.M.; Moss, F.H.; and Weingarten, R.A., "SNA Rout-
 ing: Past, Present and Possible Future," IBM Systems Jour-
 nal, vol. 22, No. 4, 1983, pp. 417-434.*

* cited by examiner

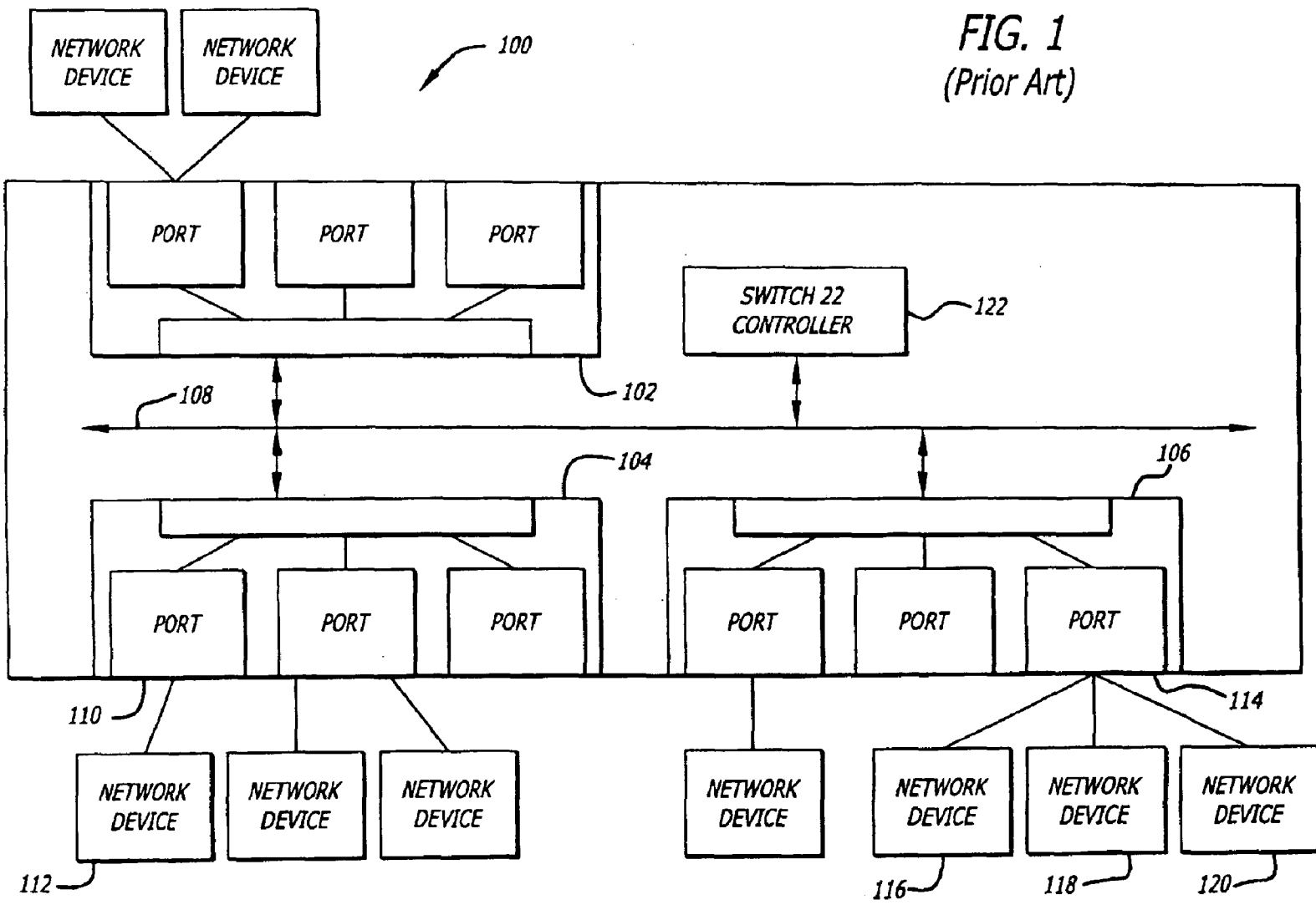

FIG. 1
(Prior Art)

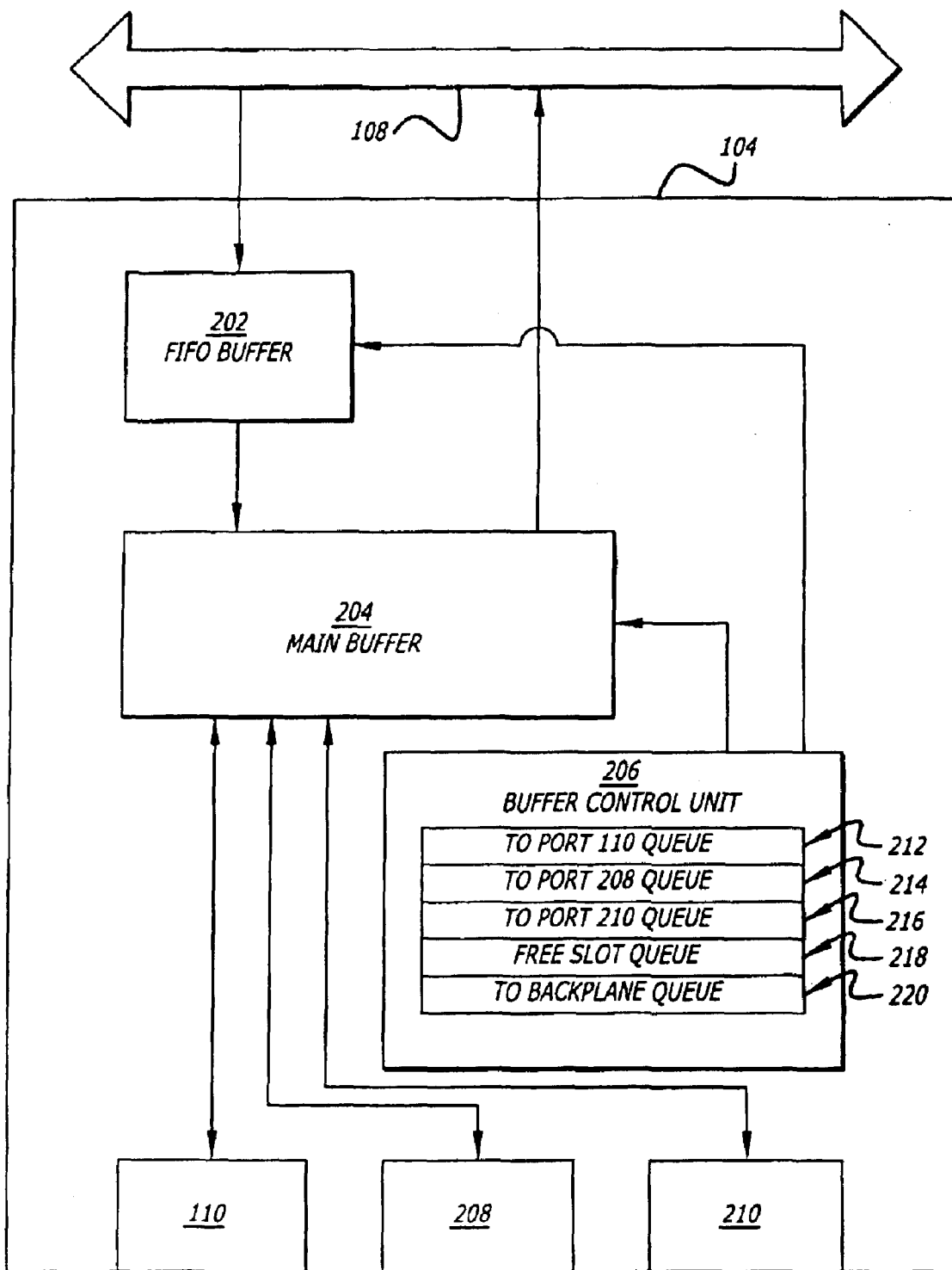

FIG. 2
(Prior Art)

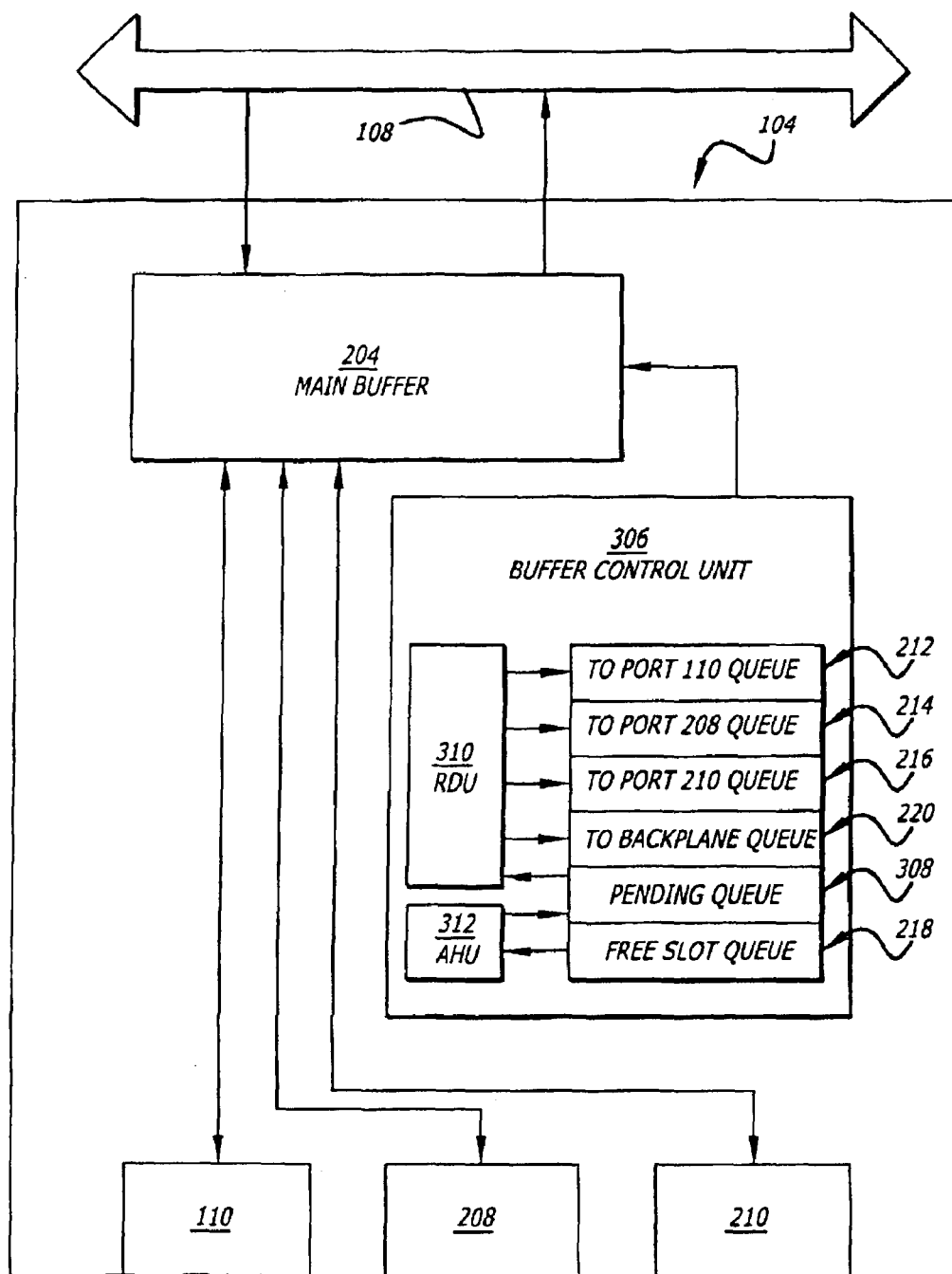

FIG. 3

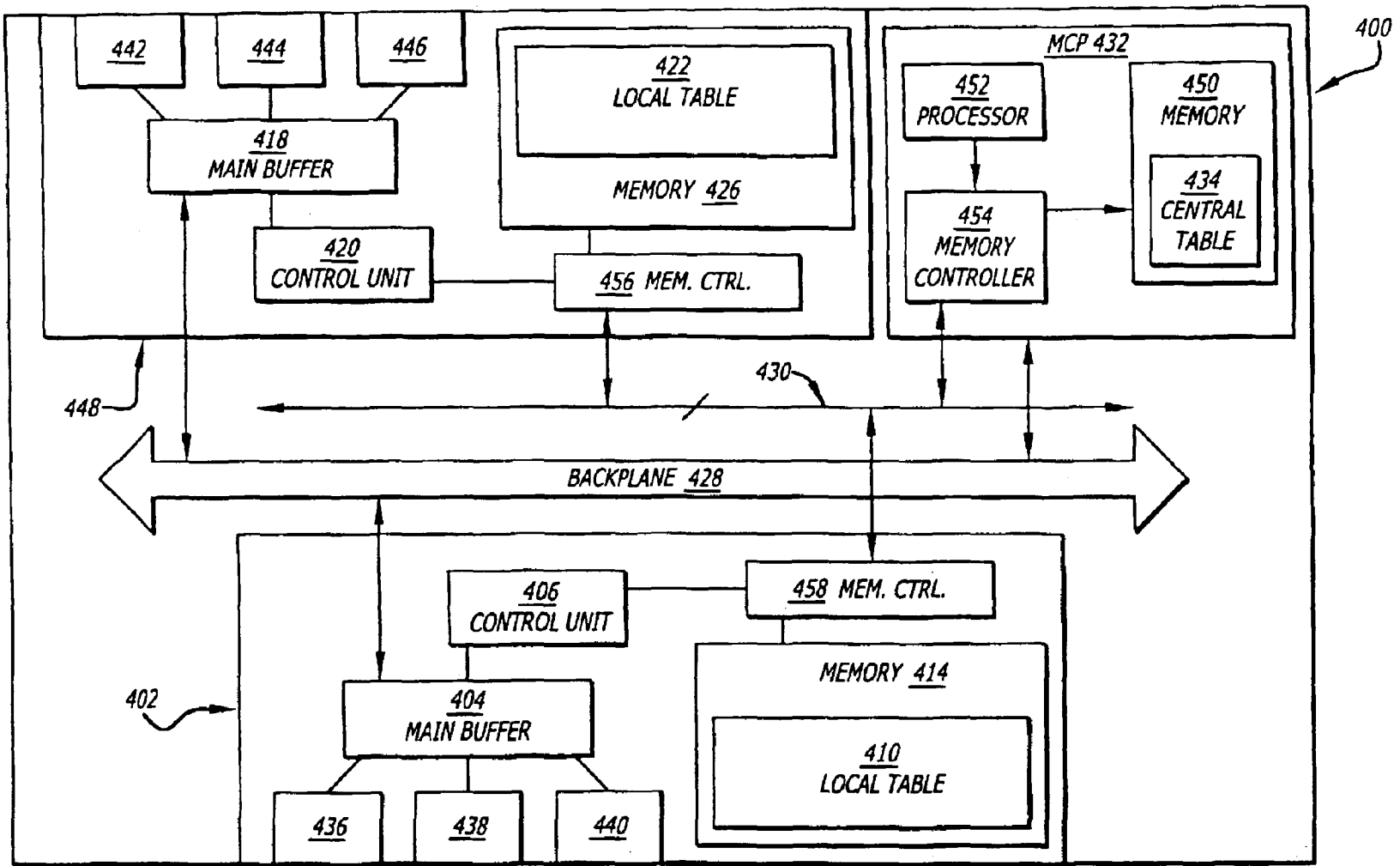

FIG. 4

METHOD AND APPARATUS FOR MANAGING THE FLOW OF DATA WITHIN A SWITCHING DEVICE

Matter enclosed in heavy brackets [] appears in the original patent but forms no part of this reissue specification; matter printed in italics indicates the additions made by reissue.

CROSS-REFERENCE TO RELATED APPLICATIONS

This application is a continuation of application Ser. No. 08/896,485, filed Jul. 17, 1997, which issued to U.S. Pat. No. 6,427,185 on Jul. 30, 2002, which is a continuation of application Ser. No. 08/526,099 filed Sep. 29, 1995 now abandoned.

FIELD OF THE INVENTION

The present invention relates to controlling data flow within a switch, and more specifically, to information distribution and buffering mechanisms for controlling data flow between multiple network interfaces over a common backplane.

BACKGROUND OF THE INVENTION

Computer networks consist of a plurality of network devices connected in a way that allows the network devices to communicate with each other. Special purpose computer components, such as hubs, routers, bridges and switches, have been developed to facilitate the process of transporting information between network devices.

FIG. 1 is a block diagram of a typical switching device 100. Switching device 100 contains slots for holding network interface cards 102, 104 and 106 and a backplane 108 for transporting information between the various interface cards 102, 104 and 106. The interface cards 102, 104 and 106 have ports that are connected to network devices that are located external to switching device 100. For example, port 110 of interface card 104 is connected to a network device 112. Port 114 of network interface card 106 is connected to network devices 116, 118 and 120.

Before switching device 100 can accurately route data between devices connected to different ports of different cards, switching device 100 must know which devices are connected to which ports. Switching device 100 obtains this knowledge by inspecting the source addresses associated with incoming data.

Typically, incoming data is encapsulated in a structure (e.g. a packet or a cell) that contains both a destination address and a source address. The destination address identifies the device or group of devices to which the data is to be sent. The source address identifies the device from which the data is sent. For the purposes of explanation, the term "cell" shall be used herein to refer to any data structure that contains data and source/destination information, including but not limited to Ethernet packets, ATM cells, and token ring packets.

When an interface card receives a cell that specifies a previously unknown source address, the interface card stores a port-to-address entry in a locally-maintained table. The interface card transmits a message to a central switch controller 122 to notify the switch controller 122 that a device with a specified address is connected to the particular port of the network interface card. Based on the information contained in this message, the switch controller 122 adds a card/

port-to-address entry in a centrally-maintained card/port-to-address table. The card/port-to-address entry indicates that the specified port of the interface card that received the cell is connected to a device that has the source address that was specified in the cell. When all interface cards on the switching device 100 report to the switch controller 122 the addresses of the devices to which they are connected to this fashion, the switch controller 122 is able to create and maintain a relatively complete table that maps addresses to ports on controller cards.

As mentioned above, switching device 100 allows network devices connected to the ports of one interface card to communicate with network devices connected to the ports of other interface cards by allowing the network interface cards to transmit information to each other over backplane 108. For example, network device 112 can communicate with network device 116 by transmitting data to interface card 104 in a cell that identifies network device 116 as the desired destination. For the purposes of explanation, it shall be assumed that the address of network device 116 is ADDR_X.

Circuitry on the interface card 104 transmits a message over backplane 108 to the switch controller 122 to indicate that the interface card 104 has received a cell with the destination address ADDR_X. Switch controller 122 searches for ADDR_X in its card/slot-to-address table to determine where interface card 104 should send the cell. In the present example, the card/slot-to-address table in switch controller 122 would contain an entry to indicate that ADDR_X is the address of a device connected to port 114 of interface card 106. The switch controller 122 transmits a message containing this information over backplane 108 to interface card 104.

Based on the information contained in the message, interface card 104 routes the cell over the backplane 108 to interface card 106. Interface card 106 receives the cell from backplane 108. Upon receiving the cell, interface card 106 transmits a message over backplane 108 to switch controller 122 to inform switch controller 122 that interface card 106 has received a message with the destination address ADDR_X. Switch controller 122 transmits a message over backplane 108 to interface card 106 to form interface card 106 that address ADDR_X is associated with a device connected to port 114 of interface card 106. Based on this information, interface card 106 transmits the cell through port 114 to device 116.

One significant disadvantage of routing cells through switching device 100 in the manner described above is that the messages that are sent between the switch controller 122 and the various interface cards to determine the appropriate routing paths are sent over backplane 108. Consequently, less bandwidth is available for transmitting the actual cells between the interface cards.

A second disadvantage to the switching scheme described above is the amount of time that elapses between when an interface card receives a cell and the time at which the interface card knows where to send the cell. During this time interval, the interface card may receive a whole series of cells for the same destination. To prevent data loss, the interface card would have to include a much larger buffer than would otherwise be required if the interface card could immediately retransmit the cell.

In an alternate approach, the interface card does not wait for the reply from the switch controller 122. Rather, the interface card simply transmits the cells that it does not know how to route to the switch controller 122. The switch controller 122 retransmits the cells to the appropriate desti-

nation based on information contained in its table. The switch controller also transmits the appropriate routing information to the interface card so that the interface card will be able to route cells with that destination address in the future.

One disadvantage of this approach is that the same cells are routed over the backplane twice, increasing the amount of traffic on the backplane. A second disadvantage of this approach is that it places a heavy burden on the switch controller, because at any given time every interface card in the switch could be sending cells for the switch controller to reroute.

A third disadvantage is that cells may arrive at their intended destination out of sequence. For example, an interface card may receive a series of cells 1 . . . N for an unknown destination. Initially, the interface card sends the cells to the switch controller. After the interface card has sent M (where $1 < M < N$) cells to the switch controller, the interface card receives the reply message from the switch controller that indicates how to route the cells. The interface card will then transmit the remaining cells (M+1) . . . N directly to the appropriate card/port. In this scenario, cell M+1 is likely to arrive at the destination card/port prior to cell M, since cell M is sent to the switch controller first.

In another alternative approach, each interface card within switching device 100 can locally store a complete card/port-to-address table. According to this approach, each interface card that detects a new source address will place a message on backplane 108 that indicates the card and slot on which the message with the new source address was received. Each interface card would read the message off the backplane 108 and add the appropriate card/port-to-address entry in its own table. Thus, when an interface card receives a cell, the interface card can quickly determine the appropriate destination for the cell from its own table without having to send or receive messages over the backplane 108. By reducing the messaging traffic over backplane 108, the throughput of switching device 100 is increased. By reducing the delay between receipt of a cell and transmission of the cell, the buffer size within each interface card can be reduced.

An approach in which each interface card maintains a complete card/port-to-address table, such as the approach described above, has the disadvantage that the table may become very large. Each card would have to reserve large amounts of memory to store the table, and contain the control circuitry for managing a large table. Further, each interface card will typically only use a relatively small amount of the data stored in the table. For example, interface card 104 will never need to know the addresses of devices connected to interface card 106 that only communicate with other devices connected to interface card 106.

Even when a local card/port-to-address table is used by an interface card to determine how to route a cell, there is some interval between the time at which the cell is received by the interface card and the time at which the cell is transmitted by the interface card. During this interval, the cell must be stored somewhere within the interface card. FIG. 2 illustrates a typical buffer mechanism 200 that may be employed by interface card 104 to store cells during this interval.

Referring to FIG. 2, it illustrates the buffering circuitry of interface card 104 of FIG. 1 in greater detail. Interface card 104 includes a first-in-first-out (FIFO) buffer 202, a buffer control unit 206 and a main buffer 204. FIFO buffer 202 is coupled between backplane 108 and main buffer 204. Buffer control unit 206 is coupled to and controls both FIFO buffer 202 and main buffer 204. In addition to port 110, interface

card 104 includes ports 208 and 210. Ports 110, 208 and 210 are coupled to main buffer 204.

The main buffer 204 is used to temporarily store both data cells that are to be transmitted out ports 110, 208 and 210, and data cells that are to be transmitted to backplane 108. The main buffer 204 includes a plurality of cell slots, each of which is capable of storing one cell of data.

Buffer control unit 206 maintains a plurality of queues, including one queue (212, 214 and 216) for each of ports 110, 208, and 210, a queue 220 for backplane 108, and a "free slot" queue 218. Buffer control unit 206 stores pointers to the cell slots of main buffer 204 in the various queues. Specifically, each cell slot within main buffer 204 has a unique pointer. The pointer to each cell slot of main buffer 204 is stored in the queue that corresponds to the destination of the data that is currently stored within the cell slot. For example, if a cell slot currently stores data to be sent on the backplane 108, then the pointer to the cell slot is stored in the queue 220 that corresponds to the backplane.

When interface card 104 receives a cell, the interface card 104 must determine the destination of the cell, as described above. Once the destination of the cell has been determined, buffer control unit 206 causes the cell to be stored in main buffer 204 and updates the queues to reflect that the cell is to be sent to the appropriate destination.

Specifically, when a cell is to be sent out a port, the pointer to the cell slot in which the cell resides is placed in the queue associated with the port. When a cell is to be transmitted over the backplane 108, the buffer control unit 206 places the pointer to the cell slot in which the cell resides in the queue 220 associated with the backplane 108.

When a cell of data is transmitted by interface card 104, the cell slot that contained the cell no longer contains data to be transmitted. To indicate that the cell slot is now available to store incoming data, the buffer control unit 206 places the pointer to the cell slot in the free slot queue 218. When storing a cell of data in main buffer 204, the buffer control unit 206 pulls a pointer from the free slot queue 218, and uses the cell slot indicated by the pointer to store the cell of data.

At any given moment all of the other interface cards on backplane 108 may be placing cells on backplane 108 that are destined for devices connected to interface card 104. To process the cells without losing data, interface card 104 must be able to sustain, for at least brief periods of time, a backplane-to-card transfer rate equal to the maximum transfer rate supported by backplane 108 (e.g. 3.2 gigabytes per second).

Typically, buffer control unit 206 determines the appropriate destination for cells at a rate (e.g. 1.2 gigabytes per second) that is slower than the maximum transfer rate of the backplane 108. Therefore, to sustain brief periods in which cells arrive at the high transfer rate of the backplane 108, the information contained on backplane 108 is transferred from the backplane 108 into the high speed FIFO buffer 202 of interface card 104. During the interval in which a cell is stored in FIFO buffer 202, interface card 104 determines the destination of the cell. Once the destination of the cell has been determined, buffer control unit 206 removes the cell from FIFO buffer 202 and stores the cell in the main buffer 204.

The buffering system illustrated in FIG. 2 has the significant disadvantage that high speed FIFO buffers are expensive. Further, every interface card in the switch must have its own of FIFO buffer to support the maximum transfer rate of the backplane. Consequently, the increased cost of high speed FIFO buffers is incurred for every interface card in the switch.

Based on the foregoing, it is clearly desirable to provide a switching device in which the delay between when an interface card receives a cell and the time at which the interface card transmits the cell is reduced. It is further desirable to provide a switching device in which the amount of traffic on the backplane that is used to determine how to route cells is reduced. Further, it is desirable to reduce the size and complexity of tables that are maintained locally in interface cards. In addition, it is desirable to provide a buffering system that allows interface cards to receive data off the backplane at the backplane's maximum transfer rate without requiring the use of high speed FIFO buffers.

SUMMARY OF THE INVENTION

A method and apparatus for managing the flow of data within a switching device is provided. The switching device includes network interface cards connected to a common backplane. Each interface card is configured to support the maximum transfer rate of the backplane by maintaining a "pending" queue to track data that has been received but for which the appropriate destination has not yet been determined. The switching device includes a switch controller that maintains a central card/port-to-address. When an interface card receives data with a destination address that is not known to the interface card, the interface card performs a direct memory access over a bus that is separate from the backplane to read routing data directly from the central table in the switch controller. Each interface card builds and maintains a routing information table in its own local memory that only includes routing information for the destination addresses that the interface card is most likely to receive.

BRIEF DESCRIPTION OF THE DRAWINGS

The present invention is illustrated by way of example, and not by way of limitation, in the figures of the accompanying drawings and in which like reference numerals refer to similar elements and in which:

FIG. 1 is a block diagram of a generic switching device;

FIG. 2 is a block diagram that illustrates the buffering system used in a prior art network interface card;

FIG. 3 is a block diagram that illustrates a buffering system according to an embodiment of the present invention; and

FIG. 4 is a block diagram that illustrates a switching device in which destination address is distributed to local tables using direct memory access techniques according to an embodiment of the invention.

DETAILED DESCRIPTION OF THE PREFERRED EMBODIMENT IMPROVED BUFFER MECHANISM

Referring to FIG. 3, it illustrates the interface card 104 of FIG. 2 with a buffer control unit 306 according to an embodiment of the present invention. Similar to the buffering mechanism illustrated in FIG. 2, buffer control unit 306 includes a plurality of queues, including queues 212, 214, and 216 that correspond to ports 110, 208 and 210, a queue 220 that corresponds to the backplane 108, and a free slot queue 218. In addition, buffer control unit 306 includes a pending queue 308. As shall be described hereafter, buffer control unit 306 uses pending queue 308 in a way that allows buffer control unit 306 to transfer cells off the backplane 108 directly into main buffer 204 at the maximum transfer rate of the backplane 108. Consequently, the need for a high speed FIFO buffer is eliminated.

When interface card 104 detects a cell on backplane 108 that is destined for interface card 104, an arrival handling unit (AHU) 312 within buffer control unit 306 pulls the pointer from the head of free slot queue 218 and places the cell directly in the cell slot that corresponds to the pointer. Ideally, the arrival handling unit 312 would then attach the pointer to the tail of the queue that corresponds to the destination of the cell. However, as mentioned above, there is not enough time to determine the destination of a cell before arrival handling unit 312 must be available to handle the arrival of a subsequent cell.

Rather than immediately determine the destination of the cell as it is stored in main buffer 204, arrival handling unit 312 simply snoops the destination address from the cell and places into the pending queue 308 both the destination address and the pointer to the cell slot into which the cell was placed. Because no destination determination is performed during this process, arrival handling unit 312 is able to place cells into main buffer 204 at the maximum transfer rate of backplane 108.

Buffer control unit 306 includes a route determination unit (RDU) 310 that sequentially removes entries from the head of the pending queue 308 and determines where cells that have the destination address contained in the entries should be routed. When route determination unit 310 determines the proper route for the destination address contained in an entry, the pointer in the entry is placed in the queue that corresponds to the determined route.

Typically, the route determination unit 310 will not be able to determine the route that corresponds to a destination address in the amount of time that it takes for a subsequent cell to arrive on backplane 108. Consequently, when cells for interface card 104 are arriving on backplane 108 at the maximum transfer rate of backplane 108, the size of the pending queue will increase. However, in typical applications, there will also be periods of relatively low cell arrival rates. During these periods, route determination unit 310 will be removing entries from pending queue 308 faster than the arrival handling unit 312 is adding entries to the pending queue 308.

According to one embodiment, buffer control unit 306 is implemented in an application specific integrated circuit (ASIC). However, many alternative implementations are possible. For example, the destination determination unit 310 and the arrival handling unit 312 may be implemented by separate hardwired circuitry, or by programming one or more processors to perform the described functions. The present invention is not limited to any particular implementation of buffer control unit 306.

ROUTE DETERMINATION MECHANISM

The mechanism used by route determination unit 310 to determine the proper route for cells based on the destination address contained within the cells significantly affects the cost and efficiency of the switching device in which buffer control unit 306 is used. As mentioned above, interface cards can determine this information by communicating over the backplane 108 with a switch controller 122 that contains a central card/port-to-address table, or by each maintaining their own card/port-to-address table. However, each of these options has significant disadvantages. The approach in which cards send messages to request the required information from the switch controller 122 is relatively slow and uses valuable bandwidth on the backplane. The approach in which each interface card maintains its own complete table requires each card to dedicate a relatively large amount of resources for creating and maintaining the table.

Referring to FIG. 4, it illustrates a switching device 400 configured according to one embodiment of the invention. Switching device 400 includes a backplane 428, two interface cards 448 and 402, and a master control process (MCP) 432. Master control process 432 includes memory 450, a memory controller 454, and a processor 452. For the purposes of explanation, the master control process 432 is illustrated as an independent component of switching device 400. However, the master control process 432 may actually reside on one of the network interface cards in switching device 400.

Each of the interface cards 402 and 448 includes a plurality of ports, a main buffer, a control unit, a memory controller and a local memory. Specifically, interface card 448 includes three ports 442, 444 and 446, main buffer 418, control unit 420, memory controller 456 and memory 426. Interface card 402 includes three ports 436, 438 and 440, a main buffer 404, control unit 406, memory controller 458 and memory 414. The control units 420 and 406 generally represent control circuitry which performs various control functions, including the functions described above with respect to buffer control units. Control units 420 and 406 may be implemented using hard-wired circuitry, a programmed processor, or a combination of hard-wired and programmed circuitry.

In addition to backplane 428, switching device 400 includes a bus 430. Bus 430 is a multiple-line bus (e.g. 16 lines) that interconnects the memory controllers on all of the interface cards and on the memory controller in the master control process 432. Bus 430 is separate from the path of the normal data flow within switching device 400, which occurs over backplane 428. Consequently, the presence of signals on bus 430 has no effect on the overall data flow over backplane 428.

COMBINED MEMORY SPACE

Each of memories 426, 450 and 414 is assigned an address space that does not overlap with the address space assigned to any other of the memory devices within switching device 400. For example, memories 426, 450 and 414 may be respectively assigned the address spaces 0 to N, (N+1)+M, and (M+1) to L. The address space covered by all of the memories 426, 450 and 414 (e.g. 0 to L) is referred to herein as the combined address space.

Each of memory controllers 454, 456, and 458 is able to directly perform memory transactions on data stored anywhere within the combined address space. An operation that is to be performed on data that is stored in memory that is not local (with respect to the memory controller that will perform the operation) is performed over bus 430. Bus 430 may be, for example, a multiplexed channel in which a memory controller places an address on the bus 430 during the first half of a clock-cycle, and the memory that includes the memory location specified in the address places the data that resides in the memory location on the bus 430 during the second half of a clock cycle.

Because each memory controller is able to perform transfer operations on any data stored within the combined address space, the control units 406 and 420 and processor 452 are able to request memory operations to be performed on any data in the combined address space, regardless of the location of the memory that contains the data involved in the operation. Further, according to one embodiment of the invention, each control unit is completely unaware of the address boundaries between the various memory devices. The fact that some of the transfer operations are taking place

over bus 430 is completely transparent to the control units 420, 406 and processor 452.

For example, control unit 406 may request data to be copied from a first memory location to a second memory location. The control unit 406 is completely unaware of where the memory device(s) that correspond to the first and second memory locations actually reside. For the purposes of explanation, it shall be assumed that the first memory location resides in the address space of memory 426, while the second memory location resides in the address space of memory 414.

To perform the requested operation, control unit 406 simply requests memory controller 458 to perform the memory transfer. Memory controller 458 retrieves data from the first location by reading the data from the appropriate memory location in memory 426 over bus 430. Memory controller 458 then stores the data at the appropriate location in memory 414.

DIRECT ACCESS OF THE CENTRAL TABLE

According to one embodiment of the invention, the central card/port-to-address table 434 is stored in the memory 450 of the master control process 432. The location at which each entry is stored in the table 434 is determined by performing a hash function on the address associated with the entry. The hash function may consist of extracting the lower N bits from the address, for example. Collisions may be resolved by any one of numerous collision resolution techniques. The present invention is not limited to any particular hash function or collision resolution technique.

When an interface card receives a cell, the control unit on the interface card reads the destination address from the cell and performs the hash function on the destination address. The result of the hash function is used as an index into central table 434. The control unit transmits control signals to the memory control unit associated with the control unit, causing the memory control unit to retrieve data from the memory location that corresponds to the index. The memory control unit performs the transfer operation over bus 430. The control unit uses the retrieved information to determine where to transmit the received cell.

As mentioned above, one disadvantage of the prior art approach to having a single card/port-to-address table is that the messages required to transfer the appropriate routing data from the master control process 432 to the various interface cards create traffic over backplane 428 that reduces the bandwidth available for card-to-card cell transfers. A second disadvantage is the amount of time required to generate the request and reply messages.

However, the embodiment illustrated in FIG. 4, which uses a separate bus 430 that allows each interface card to directly access the entire combined memory, overcomes both of these disadvantages. Specifically, data transfers occur over a bus 430 that is separate from the backplane 428, so no backplane traffic is generated.

In addition, the direct memory accesses performed over bus 430 are only slightly slower than local memory accesses. Therefore, the time delay between the arrival of a cell and the time at which the appropriate routing for the cell is determined is significantly reduced. In the preferred embodiment, the entire routing determination operation is completed for each cell by the time the interface card must be processing the subsequent cell.

Additional advantages are derived by allowing each interface card to directly address the combined address space of switching device 400. For example, the combined address

space includes the memory address of each of the ports on each of the interface cards. Consequently, an interface card can write to the address associated with the port on another card to send data directly out the port that corresponds to the address. Thus, one card can cause data to be sent directly out the port of another card without involving the control circuitry of the other card.

LOCAL TABLES

The embodiment described above overcomes many of the disadvantages of the prior art. However, the numerous memory accesses that would be performed over bus 430 in a switching device that has a large number of interface cards may exceed the throughput of bus 430. Further, if the central table 434 became corrupted or MCP 432 ceased to function properly, the entire switching device 400 would cease to function.

To resolve these problems, the interface cards are configured to store in their local memories the portions of the central table 434 in which they are most interested. According to one embodiment, each interface card maintains its own local table. In the illustrated embodiment, interface card 402 includes a local table 410 stored in memory 414. Interface card 448 includes a local table 422 stored in memory 426. Initially, these tables are empty.

Interface cards add entries to their local tables only as needed. For example, assume that interface card 402 receives a cell. The cell is stored in a cell slot of main buffer 404. An entry containing (1) the pointer of the cell slot and (2) the destination address contained in the cell is placed on the pending queue. When the entry is at the head of the pending queue, the control unit 406 does not immediately invoke a memory operation to retrieve information from the central table 434 in MCP 432. Rather, control unit 406 inspects the local table 410 to determine whether an entry associated with the destination address resides in the table 410. If the local table contains an entry associated with the destination address, then the appropriate routing for the packet is determined based on the information in the entry, and the pointer to the cell slot is placed in the appropriate queue(s).

If the local table 410 does not contain an entry associated with the destination address contained within the cell, then the control unit 406 causes information from the appropriate entry of the central table 434 to be retrieved over bus 430 through a direct memory access operation, as described above. The entry from the central table 434 identifies the card and/or port to which the received cell is to be transmitted. Based on this information, the control unit 406 places the pointer to the cell slot in which the cell resides in the appropriate queue.

In addition to placing the pointer in the appropriate queue, control unit 406 generates an entry for table 410 based on the information retrieved from central table 434. The information stored in the local table 410 includes information that indicates to where cells that contain the destination address in question should be routed. Therefore, when interface card 402 receives cells with the same destination address in the future, control unit 406 will be able to determine the appropriate routing of the cells without having to access the central table 434 stored in the MCP 432.

According to one embodiment of the invention, the entry that corresponds to a given address is stored in the local table at a location based on the index created by performing a hash function on the address. The entry for a particular address may contain, for example, the following information: a routing

tag, address information, a collision pointer, an "identical address" flag, and aging information.

The routing tag is a tag that indicates the card(s) and port(s) to which cells with the particular address are to be routed. According to one embodiment of the invention, the routing tag is a "destination tag", and each interface card is configured with a mechanism to route cells to the appropriate cards and ports based on the destination tag. A system that employs destination tags to route packets between interface cards connected to a common backplane is described in U.S. patent application Ser. No. 08/501,483 entitled METHOD AND APPARATUS FOR CONTROLLING DATA FLOW WITHIN A SWITCHING DEVICE that was filed on Jul. 12, 1995 by Ferguson, now U.S. Pat. No. 5,732,080 the contents of which are incorporated herein by reference.

The address information contained in an entry is information that allows an interface card to determine the full address that corresponds to the entry. For example, in a system where a portion of the full address is used as an index to the entry, the entry may contain the portion of the address that was not used as the index. The full address associated with an entry may therefore be determined based on the location of the entry within the local table and the portion of the address that is contained within the entry. It may be important to be able to determine the full address associated with an entry in order to resolve collisions when two addresses hash to the same index.

The collision pointer is index that points to the memory location of an entry that collided with the current entry. If no collision has occurred, then the collision pointer is NULL. The "identical address" flag indicates whether the destination address that corresponds to this entry is identical to the destination address that corresponds to another entry.

The aging information indicates how much time has elapsed from the transmission of the last packet destined to the address. According to one embodiment, the control unit on a card uses the aging information to delete entries that correspond to addresses that have not been used for longer than some specified amount of time. By deleting entries that correspond to addresses that have not been used for some period of time, the size of the local table is kept to a minimum. If a packet with an address that corresponds to an entry arrives after the entry has been deleted, the interface card must again read information from the central table 434 to recreate the entry in the local table.

In the worst case scenario, the operations involved in determining the destination for a cell include accessing local tables, calculating a memory location, performing a direct memory access to retrieve data from the memory location, and updating local tables. None of these operations require the involvement of off-card processors or control units, nor do they generate any traffic over the backplane. Consequently, even in the worst case, an interface card is able to determine the appropriate routing of a cell prior to the time at which the interface card must begin to process a subsequent cell.

The local table within any given interface card will typically only contain a relatively small portion of the information stored in the central table 434. Consequently, the amount of resources required in each interface card to create and maintain the tables is relatively small. Further, the information contained in the local memory of an interface card will be the most relevant information for that particular interface card.

Using the techniques described above, each interface card gradually builds its own local table. If an interface card has

already received a cell for a particular destination, then the interface card will not have to perform memory accesses over bus 430 to process subsequent cells for the same destination. Rather, the interface card will already have stored enough information locally to determine where to send the cell without need for further interaction with the master control process 432. As a result, the amount of traffic over bus 430 is significantly reduced.

A second advantage of storing local tables within each interface card is that the failure of any one component in switching device 400 will not cause the entire switching device 400 to fail. For example, if MCP 432 ceases to function properly, then the interface cards may not be able to retrieve destination address from the central table 434. However, the interface cards will be able to continue to process cells for destinations for which the interface cards have previously received cells.

According to one embodiment, an interface card may access the local tables in other interface cards when the MCP 432 ceases to function. These accesses are performed through the same direct memory access process that interface cards use to read the entries from the central table 434. When an interface card finds an entry that corresponds to a particular address in the local table of another card, the interface card copies information from the entry into its own table, just as it does when retrieving information from the central table 434.

In the foregoing specification, the invention has been described with reference to specific embodiments thereof. It will, however, be evident that various modifications and changes may be made thereto without departing from the broader spirit and scope of the invention. The specification and drawings are, accordingly, to be regarded in an illustrative rather than a restrictive sense.

What is claimed is:

1. A switching device comprising:
 - a master control process including a memory to store routing information; and
 - a first interface card in communication with the master control process, the first interface card comprising (i) a first local memory including a plurality of entries that collectively contain a portion of the routing information stored in the memory of the master control process and (ii) a first controller to update contents of at least one entry of the first local memory from the memory of the master control process in response to an event.
2. The switching device of claim 1, wherein the event is a condition in which contents of the entry have not been accessed for longer than a specified amount of time.
3. The switching device of claim 1, wherein the event is a condition in which a cell having a destination address is received and no routing information associated with the cell is currently stored in the first local memory.
4. The switching device of claim 1 further comprising:
 - a backplane coupled to the master control process and the first interface card, the backplane to provide a medium for transmission of a cell; and
 - a bus coupled to the master control process and the first interface card, the bus to enable the first interface card to receive the portion of the routing information from the memory of the master control process.
5. The switching device of claim 4, wherein the bus enables the first interface card to perform a direct memory access on the memory of the master control process.
6. The switching device of claim 1, wherein the first interface card further comprising a control unit that controls the

first controller in performing a transfer of the portion of the routing information from the memory of the master control process into the first local memory.

7. The switching device of claim 6, wherein the control unit of the first interface card further comprising:

- a buffer;
- a plurality of queues including a pending queue; and
- an arrival handling unit coupled to the pending queue, the arrival handling unit to place a pointer into the pending queue, the pointer being associated with a cell slot of the buffer into which the cell having the destination address is placed.

8. The switching device of claim 7, wherein the control unit of the first interface card further comprising a route determination unit that sequentially removes pointers from the pending queue and determines where the cell having the destination address should be routed.

9. The switching device of claim 6, wherein the control unit is a programmed processor.

10. The switching device of claim 6, wherein the first controller and the control unit are implemented as separate circuitry.

11. The switching device of claim 1 further comprising a second interface card also in communication with the master control process, the second interface card comprises (i) a second local memory including a plurality of entries to collectively contain a portion of the routing information stored in the memory of the master control process and (ii) a second controller to update contents of at least one entry of the second local memory from the memory of the master control process.

12. The switching device of claim 11, wherein the portion of the routing information stored in the second local memory differs from the portion of the routing information stored in the first local memory.

13. The switching device of claim 1, wherein the master control process is a component in communication with the first interface card.

14. The switching device of claim 1, wherein the master control process is employed on a card in communication with the first interface card.

15. The switching device of claim 1, wherein the plurality of entries of the first local memory of the first interface card are organized as a table.

16. The switching device of claim 1, wherein the first controller of the first interface card to update contents of the at least one entry of the first local memory by accessing routing information from the memory of the master control process.

17. The switching device of claim 3, wherein the cell is a packet including the destination address.

18. The switching device of claim 1, wherein the first controller updates the contents by performing a direct memory access operation on the memory of the master control process.

19. A switching device comprising:

- a backplane;
- a bus;
- a master control process coupled to the backplane and the bus, the master control process including a memory to store routing information; and
- a first interface card coupled to the backplane and the bus, the first interface card comprising (i) a first local memory including a plurality of entries that collectively contain a portion of the routing information stored in the memory of the master control process and (ii) a first

13

controller to receive the portion of the routing information from the memory of the master control process via the bus upon receiving data that includes a destination address about which no routing information is currently stored in the first local memory.

20. The switching device of claim 19, further comprising a second interface card that comprises (i) a second local memory including a second portion of the routing information stored in the memory of the master control process and (ii) a second controller to receive the second portion of the routing information from the memory of the master control process upon receiving data that includes a destination address about which no routing information is currently stored in the second local memory.

21. The switching device of claim 19, wherein the second portion of the routing information stored in the second local memory differs from the portion of the routing information stored in the first local memory.

22. The switching device of claim 19, wherein the portion of the routing information is a subset of the routing information stored in the memory of the master control process.

23. The switching device of claim 20, wherein the bus is a multiple line bus that interconnects the first and second controllers of the first and second interface cards respectively.

24. The switching device of claim 19, wherein the first interface card further comprising a control unit that controls the first controller in performing a transfer of the portion of the routing information from the memory of the master control process into the first local memory.

25. The switching device of claim 24, wherein the control unit of the first interface card further comprising:

a buffer;

a plurality of queues; and

an arrival handling unit coupled to at least one of the plurality of queues, the arrival handling unit to place a pointer into an entry of the one of the plurality of queues, the pointer being associated with a location of the buffer into which the data having the destination address is placed.

26. The switching device of claim 25, wherein the data is a cell.

27. The switching device of claim 26, wherein the control unit of the first interface card further comprising a route determination unit that sequentially removes pointers from the one of the plurality of queues and determines where the cell having the destination address should be routed.

28. The switching device of claim 19, wherein the master control process resides on a second card coupled to the backplane and the bus.

29. The switching device of claim 19, wherein the memory of the master control process stores a card/port-to-address table to contain the routing information.

30. The switching device of claim 29, wherein the routing information of the card/port-to-address table is indexed by performing a hash operation on at least a portion of the destination address.

31. The switching device of claim 19, wherein an address space of the memory of the master control process is non-overlapping with address space of the first local memory associated with the first interface card.

32. The switching device of claim 20, wherein an address space of the memory of the master control process is non-overlapping with address space of the first local memory and the second local memory associated with the first interface card and the second interface card, respectively.

33. The switching device of claim 20, wherein the address spaces of the first local memory of the first interface card and

14

the second local memory of the second interface card are non-overlapping with each other.

34. The switching device of claim 33, wherein the first controller is adapted to receive routing information contained in the second local memory of the second interface card.

35. The switching device of claim 19, wherein direct memory accesses by the first controller of the first interface card are performed over the bus.

36. The switching device of claim 20, wherein direct memory accesses by the first and second controllers are performed over the bus.

37. The switching device of claim 19, wherein the first controller of the first interface card inspects entries of the first local memory for an entry associated with the received data and obtains routing information associated with the received data if the entry resides in the first local memory.

38. The switching device of claim 19, where the entries of the first local memory are organized as a table.

39. The switching device of claim 19, wherein the first local memory contains the portion of the routing information by reading the portion of the routing information from the memory of the master control process.

40. The switching device of claim 19 wherein the first local memory contains the portion of the routing information by the master control process writing the portion of the routing information to the first local memory.

41. The switching device of claim 26, wherein the cell is a packet including the destination address.

42. The switching device of claim 41, wherein the control unit of the first interface card further comprising:

a buffer;

a plurality of queues including a pending queue; and

an arrival handling unit coupled to the pending queue, the arrival handling unit to place a pointer into the pending queue, the pointer being associated with a slot of the buffer into which the packet having the destination address is placed.

43. The switching device of claim 42, wherein the control unit of the first interface card further comprising a route determination unit that sequentially removes pointers from the pending queue and determines where the packet having the destination address should be routed.

44. The switching device of claim 19, wherein the bus enables a transfer of a table of routing information between the master process control and the first controller.

45. The switching device of claim 44, wherein the first controller is a memory controller.

46. The switching device of claim 44, wherein the backplane transfers the data including the destination address as a data packet.

47. The switching device of claim 19, wherein the first controller performed a direct memory access operation on the memory of the control process to receive the portion of routing information.

48. The switching device comprising:

a backplane;

a bus;

a master control process coupled to the backplane and the bus, the master control process including a memory to the store routing information; and

a plurality of interface cards coupled to the backplane and the bus, each of the plurality of interface cards including a local memory to store a table featuring a portion of the routing information and a memory controller to receive particular routing information from the memory

15

of the master control process upon receiving a cell that includes a destination address about which the particular routing information is currently not stored.

49. The switching device of claim 48, wherein the portion of the routing information stored in the local memory of a first interface card of the plurality of interface cards differs from the portion of the routing information stored in the local memory of a second interface card of the plurality of interface cards.

50. The switching device of claim 48, wherein the portion of the routing information is a subset of the routing information storing in the memory of the master control process.

51. The switching device of claim 48, wherein the bus is a multiple line bus that interconnects the memory controllers of the plurality of interface cards.

52. The switching device of claim 48, wherein the master control process resides on one of the plurality of interface cards.

53. The switching device of claim 48, wherein an address space of the memory of the master control process is non-overlapping with address spaces of each of the local memories of the plurality of interface cards.

54. The switching device of claim 53, wherein the address spaces of each of the local memories of the plurality of interface cards are non-overlapping with each other.

55. The switching device of claim 48, wherein direct memory accesses by the memory controllers of the plurality of interface cards are performed over the bus.

56. The switching device of claim 48, wherein the local memory of at least one of the plurality of interface cards contains the portion of the routing information by reading the portion of the routing information from the memory of the master control process.

57. The switching device of claim 48 wherein the local memory of at least one of the plurality of interface cards

16

contains the portion of the routing information by the master control process writing the portion of the routing information to the local memory.

58. The switching device of claim 48, wherein the cell is a packet including the destination address.

59. The switching device of claim 49, wherein the cell is a packet including the destination address.

60. The switching device of claim 50, wherein the cell is a packet including the destination address.

61. The switching device of claim 51, wherein the cell is a packet including the destination address.

62. The switching device of claim 52, wherein the cell is a packet including the destination address.

63. The switching device of claim 53, wherein the cell is a packet including the destination address.

64. The switching device of claim 54, wherein the cell is a packet including the destination address.

65. The switching device of claim 55, wherein the cell is a packet including the destination address.

66. The switching device of claim 56, wherein the cell is a packet including the destination address.

67. The switching device of claim 57, wherein the cell is a packet including the destination address.

68. The switching device of claim 48, wherein the bus couples the master control process to the memory controllers of the plurality of interface cards.

69. The switching device of claim 48, wherein the memory controller performing a direct memory access operation on the memory of the master control process to receive the particular routing information.

* * * * *